

NO	DESCRIPTION	MAT'L	Q'TY	WT(kg)	REMARKS

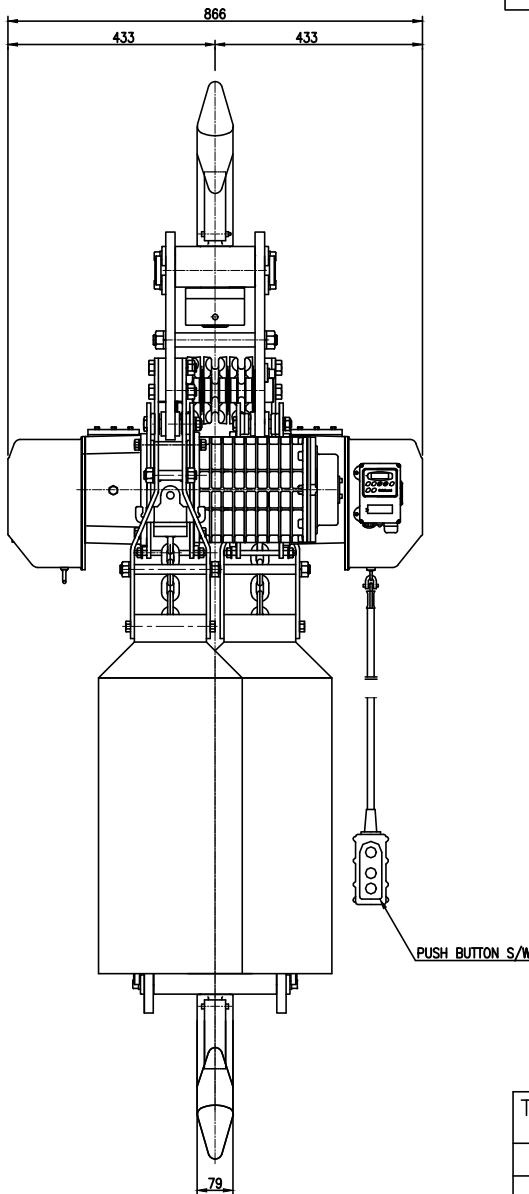
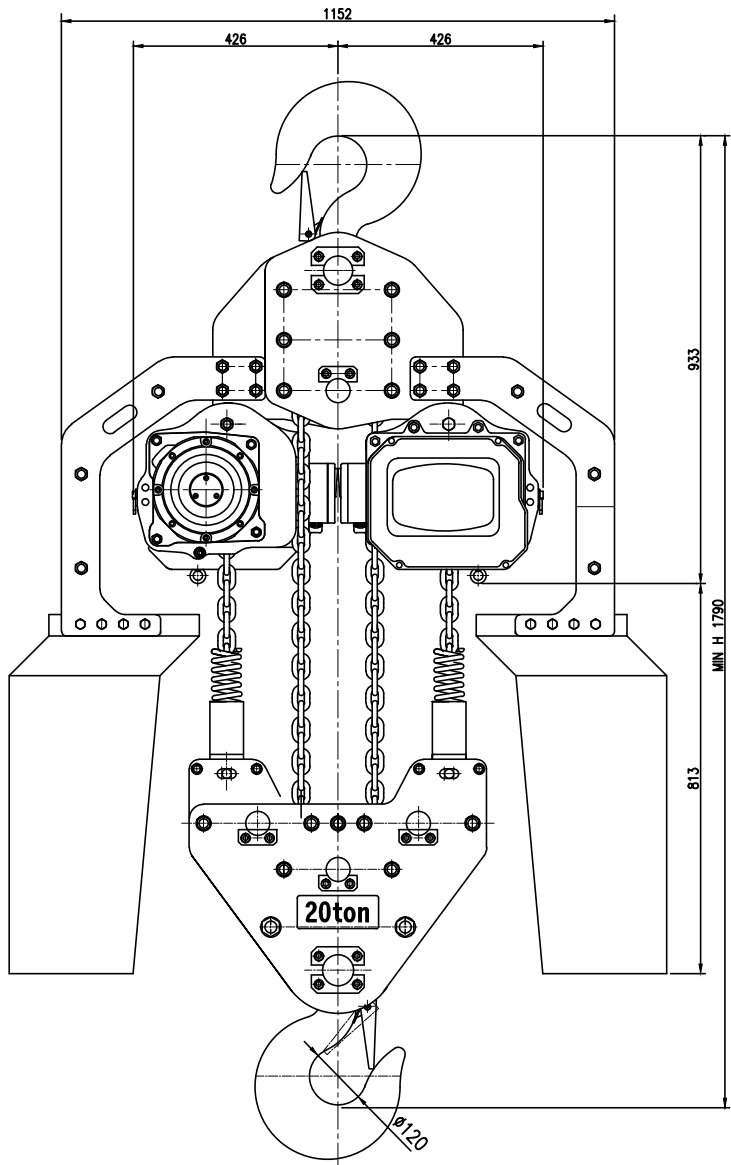

SPECIFICATION		
HOISTING LOAD	20 TON	
TESTING LOAD	25 TON	
LIFTING HEIGHT	5 M	
HOISTING	SPEED	0.67-1.6 M/MIN
	MOTOR	3.5KW x 4P x 2 SET
POWER SUPPLY	AC 220,380,440.x3ø x 60 Hz	
OPERATING METHOD	P.B type ON . FL	
WEIGHT	905 KG	

TITLE EDSA-20W CHAIN HOIST				PROJECTION	
WORK NO		WORK NAME			
				SCALE	Q'TY
				1/1	1
DRAWN	CHECKED	REVIEWED	APPROVED	DRAWING NO	
H.J		LEE	Y. K	EDSA20W01	
2020.09.14		2020.09.14	2020.09.14		

도면에 지시되지 않은 일반공차						
가공별	치수	3-6	6-30	30-120	120-315	315-1000
선	삭					
구멍간	거리	±0.1	±0.2	±0.3	±0.5	±0.8

REV.NO	DATE	REVISION DESCRIPTION	DRAWN	CHECKED	APPROVED

**DAESAN InoTEC INC**