

NO	DESCRIPTION	MAT'L	Q'TY	WT(kg)	REMARKS

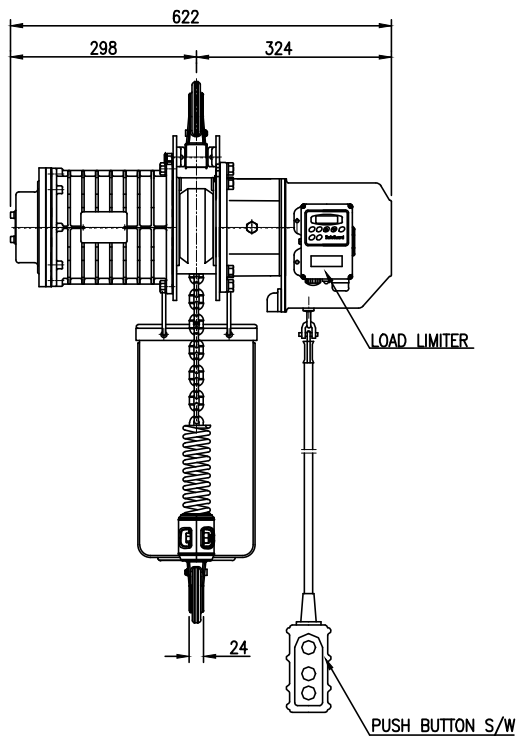
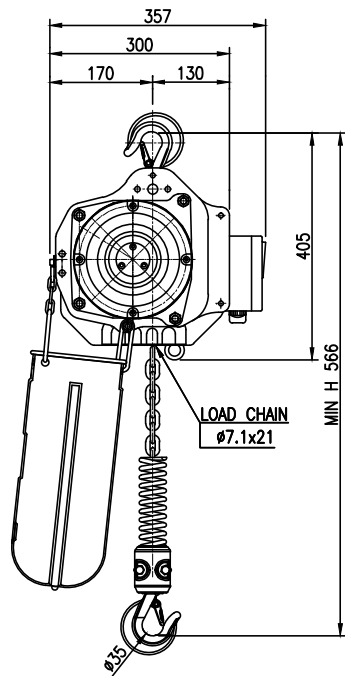

SPECIFICATION		
HOISTING LOAD	1	TON
TESTING LOAD	1.25	TON
LIFTING HEIGHT	4	M
HOISTING MOTOR	SPEED	2.2-6.4 M/MIN
		1.8 KW x 4P x 1 SET
POWER SUPPLY	AC 220, 380, 440 x 3φ x 60 Hz	
OPERATING METHOD	P.B type ON . FL	
WEIGHT	74 KG	

TITLE EDSA-1S CHAIN HOIST				PROJECTION	
WORK NO		WORK NAME			
				SCALE	Q'TY
				1/1	1
DRAWN	CHECKED	REVIEWED	APPROVED	DRAWING NO	
H.J		LEE	Y. K	EDSA01S01	
2020.09.14		2020.09.14	2020.09.14		

도면에 지시되지 않은 일반공차						
가공별	치수	3-6	6-30	30-120	120-315	315-1000
선	삭					
구멍간	거리	±0.1	±0.2	±0.3	±0.5	±0.8

REV.NO	DATE	REVISION DESCRIPTION	DRAWN	CHECKED	APPROVED

DAESAN INoTEC INC