

NO	DESCRIPTION	MAT'L	Q'TY	WT(kg)	REMARKS

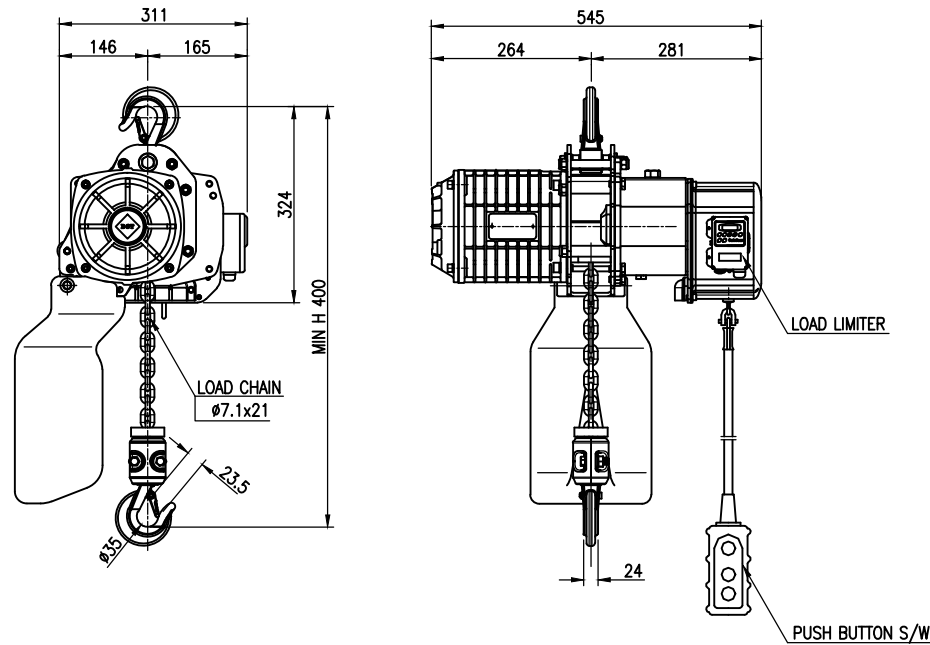

SPECIFICATION		
HOISTING LOAD	1	TON
TESTING LOAD	1.25	TON
LIFTING HEIGHT	4	M
HOISTING	SPEED	3.4/4.1 M/MIN
	MOTOR	0.8 KW x 4P x 1 SET
POWER SUPPLY	AC 220/110 x 1φ x 50/60 Hz	
OPERATING METHOD	P.B type ON . FL	
WEIGHT	60 KG	

TITLE DSS-1TON CHAIN HOIST				PROJECTION	
WORK NO		WORK NAME			
				SCALE	Q'TY
				1/1	1
DRAWN	CHECKED	REVIEWED	APPROVED	DRAWING NO	
YOO.M.R	-	LEE. H.J	Y. K	DSS010S001	
2012.07.11	-	2012.07.11	2012.07.11		
DAESAN INoTEC INC					

REV.NO	DATE	REVISION DESCRIPTION	DRAWN	CHECKED	APPROVED