

NO	DESCRIPTION	MAT'L	Q'TY	WT(kg)	REMARKS

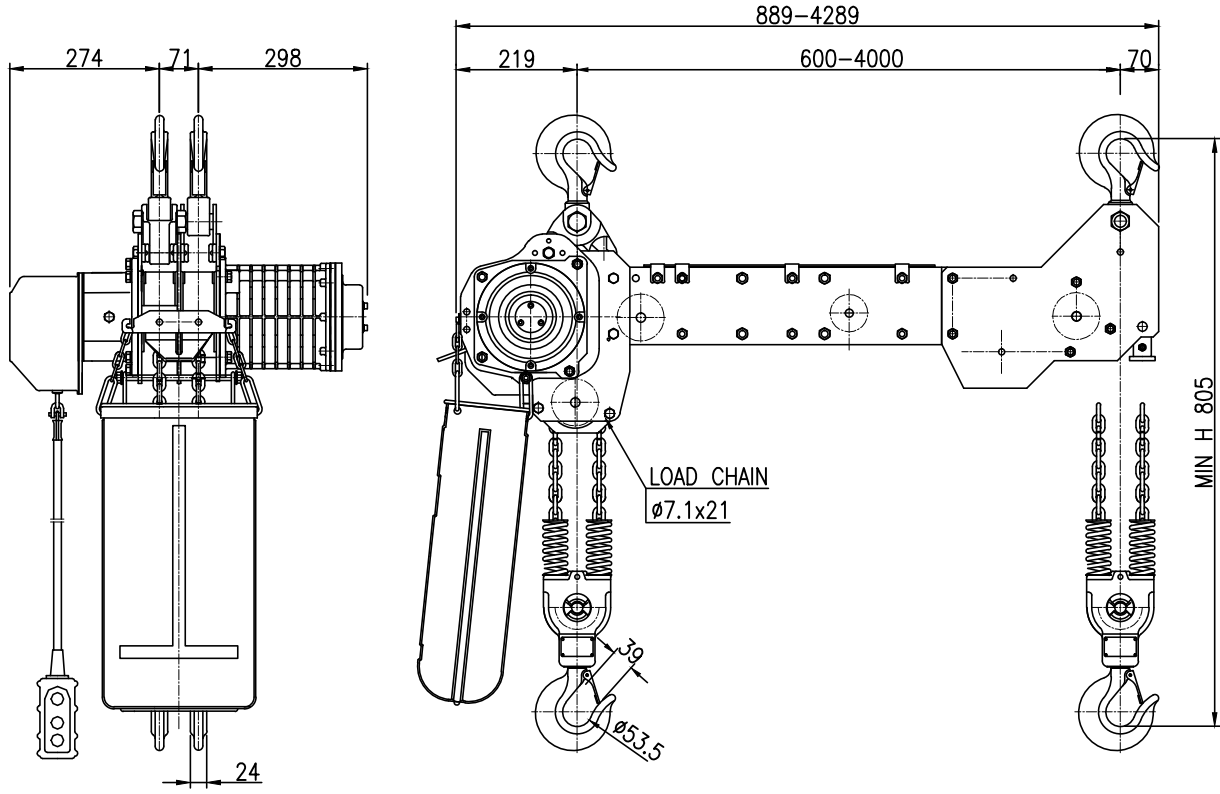

SPECIFICATION		
HOISTING LOAD	2	TON
TESTING LOAD	2.5	TON
LIFTING HEIGHT	4	M
HOISTING MOTOR	SPEED	3.4/4.1 M/MIN
		1.8 KW x 4P x 1 SET
POWER SUPPLY	AC 220,380,440,480 x 3ø x 50/60 Hz	
OPERATING METHOD	P.B type ON . FL	

TITLE DSDHA-2W CHAIN HOIST				PROJECTION	
WORK NO		WORK NAME			
				SCALE	Q'TY
				1/1	1
DRAWN	CHECKED	REVIEWED	APPROVED	DRAWING NO	
H.J	-	LEE	Y.K	DSDHA02WS1	
2012.07.11	-	2012.07.11	2012.10.17		
DAESAN INoTEC INC					

도면에 지시되지 않은 일반공차						
가공별 치수	3-6	6-30	30-120	120-315	315-1000	
선삭						
구멍간 거리	±0.1	±0.2	±0.3	±0.5	±0.8	

REV.NO	DATE	REVISION DESCRIPTION	DRAWN	CHECKED	APPROVED