

NO	DESCRIPTION	MAT'L	Q'TY	WT(kg)	REMARKS
001	LOAD CHAIN(ELECTROLESS NI PLATING)	MN-B(steel)	14M		
002	HAND CHAIN	SUS304	6M		
003	HOOK	HBsC4	1		
004	LOAD SHEAVE(ELECTROLESS NI PLATING)	FCD45	1		
005	CHAIN WHEEL(ELECTROLESS NI PLATING)	FCD45	1		
006	HEX BOLT N.S/W	SUS304	5		

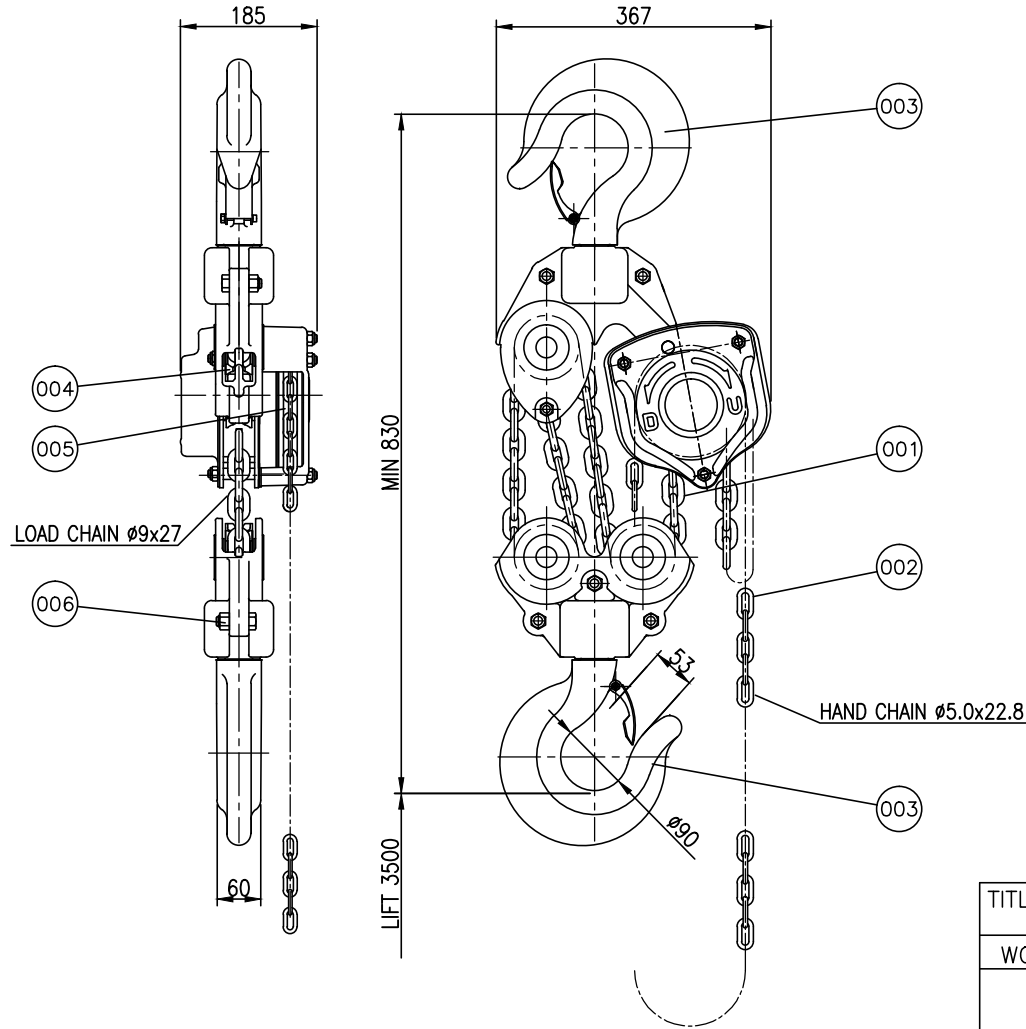

SPECIFICATION	
HOISTING LOAD	10 TON
TESTING LOAD	12.5 TON
LIFTING HEIGHT	3.5 M
HOISTING	MANUAL
WEIGHT	95 kg
LOAD CHAIN	$\phi 9 \times 27$
PULLING EFFORTS	41 KG

TITLE EXDSN-10TON CHAIN BLOCK				PROJECTION	
WORK NO		WORK NAME		SCALE Q'TY	
				1/3	1
DRAWN	CHECKED	REVIEWED	APPROVED	DRAWING NO	
KIM.T.J		LEE. H.J	Y. K	EDSN100001	
2015.02.23		2012.10.09	2012.10.09		

DAESAN INoTEC INC

REV.NO	DATE	REVISION DESCRIPTION	DRAWN	CHECKED	APPROVED