



제 2010 - 64497-1 호

안 전 인 증 서

(사업장명)

(주)대산이노텍

(소재지)

(314-821)충남 공주시 정안면 사현리 523

위 사업장에서 제조하는 아래의 품목이 산업안전보건법 제34조 및 같은 법 시행규칙 제58조의4제4항에 따른 안전인증 심사 결과 안전·보건기준에 적합하므로 안전인증표시의 사용을 인증합니다.

_____ 품 목 _____
호이스트

_____ 형식,모델(용량,등급)/인증번호 _____
DSM-1.9W (1.9Ton) /10-AQ2AC-06026

_____ 인 증 기 준 _____
노동부 고시 제2010 - 12호 (위험기계,기구 의무안전인증 고시)

_____ 인 증 조 건 _____
<사업장 소재지 변경으로 인한 재발급[최초 발행일 2010년 11월 10일]>

2012년 04월 18일

한국산업안전보건공단이사장



ON 9MG

NO	DESCRIPTION	SIZE	MAT' L	Q' TY	WT (kg)	REMARKS

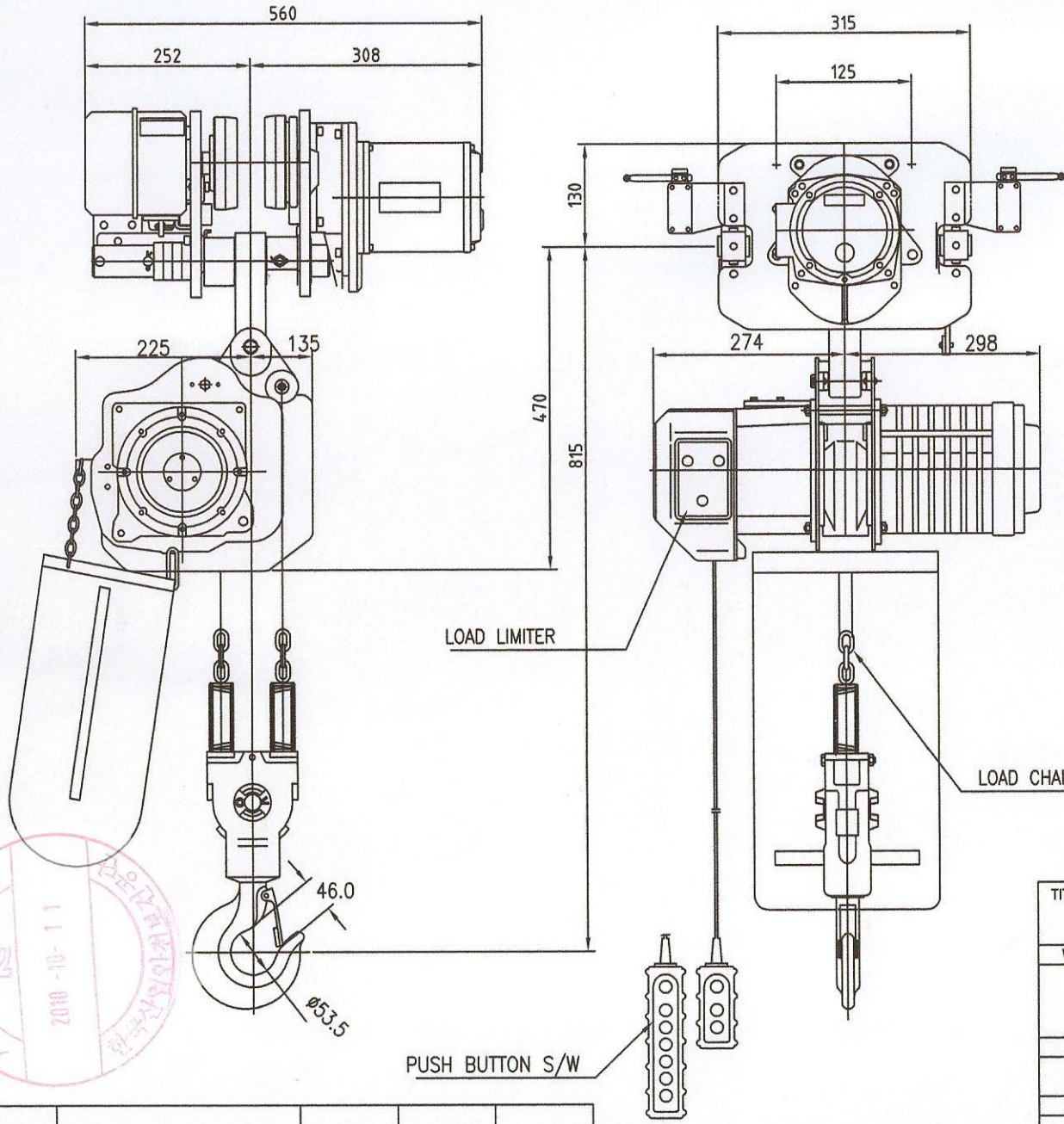

SPECIFICATION		
HOISTING LOAD	1.9	TON
TESTING LOAD	2.38	TON
LIFTING HEIGHT	50	M
HOISTING	SPEED	4.1/3.4 M/MIN
	MOTOR	1.8 KW x 1 SET
TRAVERSING	SPEED	15/12 M/MIN
	MOTOR	0.4 KW x 1 SET
POWER SUPPLY	AC 220,380,440 V x 3 ϕ x 60/50Hz	
OPERATING METHOD	P.B type ON . FL	
WEIGHT	260 KG	
LOAD CHAIN FALL	2	
I-BEAM 적용폭	100-150mm	
MIN.RADIUS OF CUVATURE(m)	1500	

* 트로리 로라 외경 : $\phi 110$

TITLE				PROJECTION	
DSM-1.9W ELECTRIC CHAIN HOIST					
WORK NO	WORK NAME			SCALE	Q' TY
	외형도			N S	1
DRAWN	CHECKED	REVIEWED	APPROVED	DRAWING NO	
y.j	won		Y.K	DSM019W	
05.11	05.11		05.11		

REV.NO	DATE	REVISION	DESCRIPTION	DRAWN	CHECKED	APPROVED

INOTEC IND. CO., LTD

FEC CHAIN

CORPORATION

TEL:+81-53-425-4116 , 2162

337 KANAORI-CHO , HAMAMATSU CITY ,

SHIZUOKA PRE.,435-0026 JAPAN

FAX:+81-53-425-5122

TEST CERTIFICATE

Distributor:	code #: 1080	distributor's name: ASAO & CO., LTD	
Coustermer:		coustermer's name:	
Article name: (Application)	Load chain for electric chain hoist		
Spec. standard	<input type="checkbox"/> DIN EN 818-7:2002 , <input type="checkbox"/> JIS B 8812:1999 <input type="checkbox"/> ISO 3077 , <input checked="" type="checkbox"/> FEC		
Material spec.:	SAE15B24(Mn-B steel)		
Finish:	<input checked="" type="checkbox"/> temper-colored, <input type="checkbox"/> zinc-plated, <input type="checkbox"/> coated() <input type="checkbox"/> zinc-phosphated, <input type="checkbox"/> manganese-phosphated <input checked="" type="checkbox"/> oiled, <input type="checkbox"/> o-oiled		
Stamping:	<input type="checkbox"/> FEC standard, <input checked="" type="checkbox"/> coustermer's request → DS, JAPAN , (Lot #), FEC#		
Product code#: description: quality type	FCD07121 φ7.1*P21 G80/ type-DAT		
Dimention:		Result	
Nominal diameter(dn)	[mm]	7.1 +0.0/-0.3	OK
Internal width,min.:	[mm]	8.8	
external width, max.:	[mm]	23.6	
Nominal pitch 1 t	[mm]	21.0 +0.3/-0.1	
5 t	[mm]	-	
11 t	[mm]	231.0 +0.3/-0.7	
Diameter at the weld(ds), max.:	[mm]	7.6	
Mechanical properties:			OK
Working load limit(WLL), max.:	[kg]	1500	
(drive mechanism g		-	
Manufacturing proof force(MPF), min.:	[KN]	40	
Stress at min. MPF		-	
Guranteed breaking force(BF), min.:	[KN]	63	
Stress at min. BF		-	
Total ultimate elongation(A), min.:	[%]	10	
Surface hardness/HV3, min.:	[-]	500	
/HV5, min.:	[-]	-	
Hardness /HRC, min.:	[-]	-	
Case depth,min.:	[mm]	0.14	
Bend deflection(f),min.:	[mm]	-	
Fatigue resistance, min.:	[cycle]	-	
Packing:			
Weight per meter:	[kg/m]	1.1	
Length 1	[meter]	200m-15/pcs	
2	[meter]	-	
Packing	-	Steel barrel	

I hereby certify above all is true.

K. Sugimura

KAZUYUKI SUGIMURA
Quality Assurance Dept.,
Chief Inspector

issued date: March 29,2010

[Note]



제 2012-BJ-0009 호



안 전 인 증 서

정호엔지니어링

경기도 광명시 노동사동 440-5

위 사업장에서 제조하는 아래의 품목이 산업안전보건법 제34조 및 같은 법 시행규칙 제58조의4제4항에 따른 안전인증 심사 결과 안전·보건기준에 적합하므로 안전인증표시의 사용을 인증합니다.

_____ 품 목 _____
양중기용 과부하방지장치

_____ 형식·모델/용량·등급/인증번호 _____
형식·모델 용량·등급 인증번호
JDL-100 J-2 12-AV2BJ-0009

_____ 인 증 기 준 _____
방호장치 의무안전인증 고시(고용노동부고시 제2010-36호)

_____ 인 증 조 건 _____
아래 주소에서 생산되는 제품에 한함.
정호엔지니어링, 경기도 광명시 노동사동 440-5

2012년 06월 11일

한국산업안전보건공단 이사장



NO	Commodity	Capacity	Q'TY	Model No.	Maker

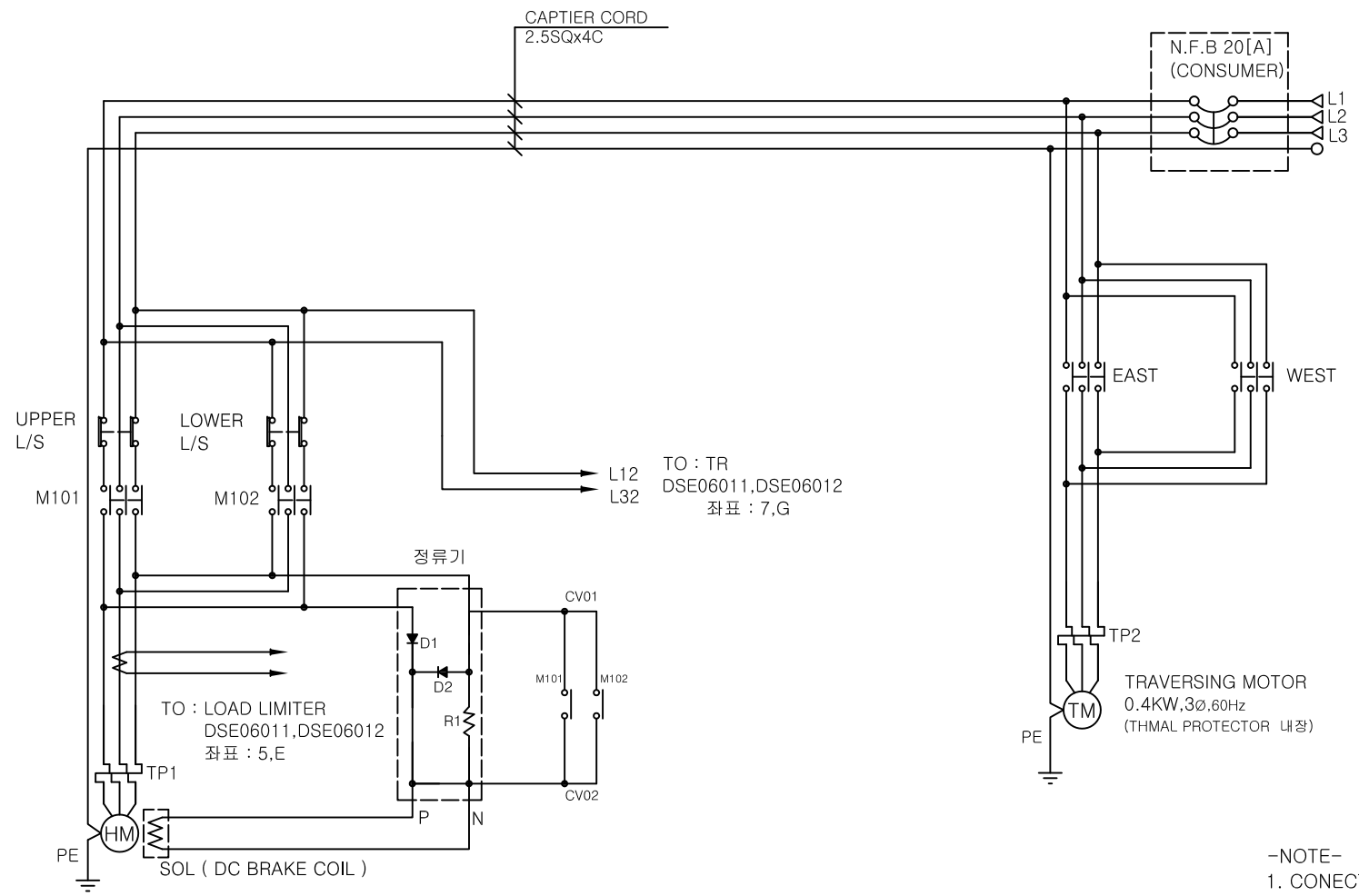

-NOTE-
1. CONECTION WIRE : 2.5SQ(흑색)

TITLE		POWER CIRCUIT DIAGRAM		PROJECTION	
WORD NO		WORK NAME			
		DSM - 1S.1.9W,2W 220,380,440[V]		SCALE	Q'TY
DRAWN	CHECKED	REVIEWED	APPROVED	DRAWING NO	
Y.D	Y.C		Y.K	DSE06009	
10.09.02	10.09.03		10.09.03		
InoTEC IND. CO., LTD.					

REV.NO	DATE	REVISION DESCRIPTION	DRAWN	CHECKED	APPROVED

NO	Commodity	Capacity	Q'TY	Model No.	Maker

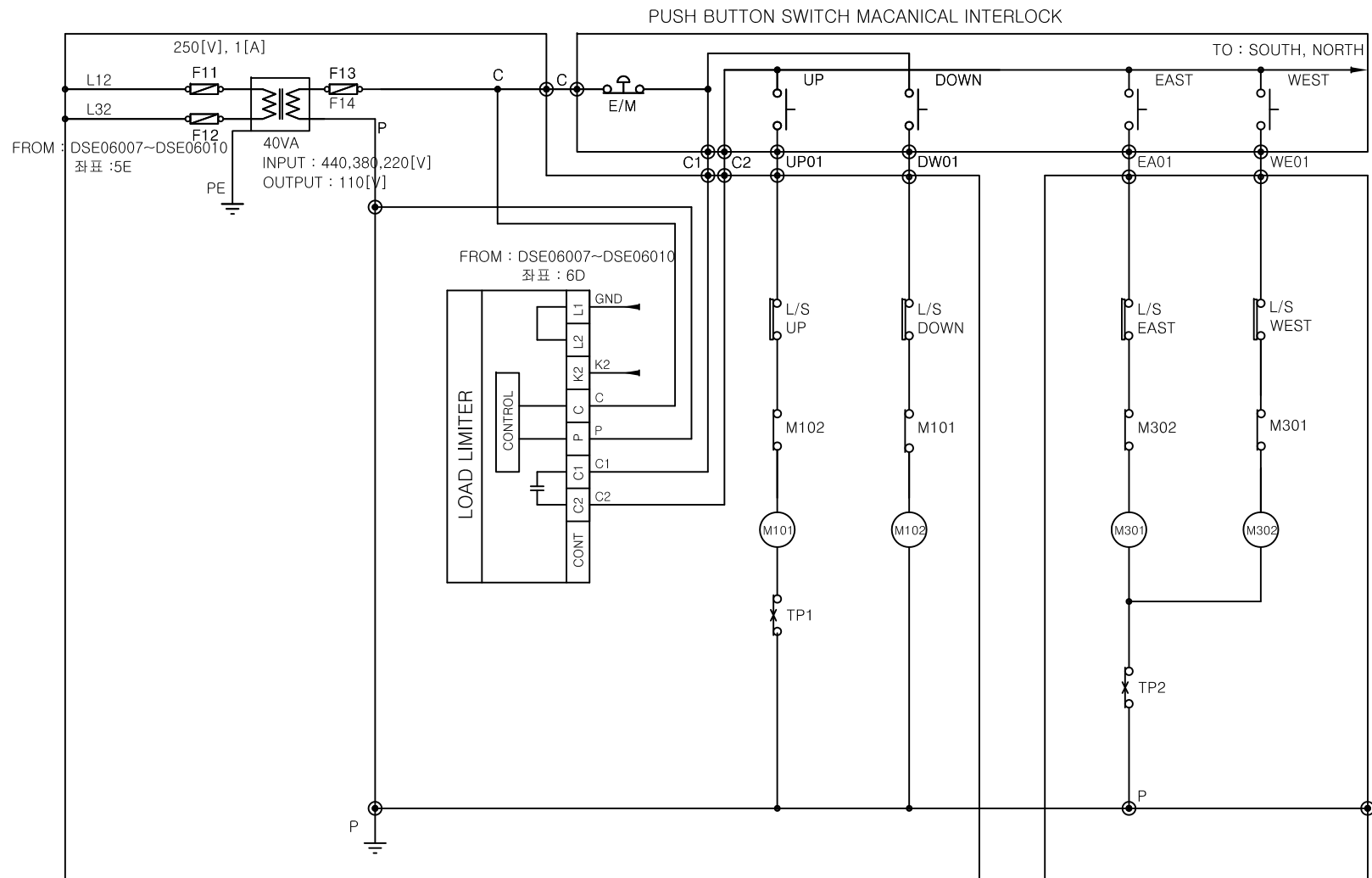

-NOTE-
1. CONNECTION WIRE
: 1.5SQ(적색)

TITLE				CONTROL CIRCUIT DIAGRAM		PROJECTION	
WORD NO		WORK NAME					
		DSM - 1S,1.5S,1.9S,1.9W,2W,2S,2.5S,3W,5W				SCALE	Q'TY
		220,380,440[V]					
DRAWN	CHECKED	REVIEWED	APPROVED	DRAWING NO			
Y.D	Y.C		Y.K	DSE06012			
10.09.02	10.09.02		10.09.03				
DAESAN INoTEC IND. CO., LTD.							

REV.NO	DATE	REVISION DESCRIPTION	DRAWN	CHECKED	APPROVED

SCHEDULE OF TECHNICAL DATA

1. SERVICE	HOISTING
2. MANUFACTURE	DAESAN INOTEC INC.
3. MOTOR MODEL NO.	DSAI - 1S - 220
4. RATED POWER	1.8 KW x 4 P
5. RATED VOLTAGE AND FREQUENCY	220 V 60 HZ
6. MOTOR TYPE	SQUIRREL CAGE ROTOR YPE
7. RATING	30 MIN
8. LOCATION	IN-DOOR , OUT-DOOR
9. INSULATION CLASS	B
10. DESING TEMPERATURE RISE (BY RESISTANCE)	80°C
11. FULL LOAD SPEED	1740 RPM
12. FULL LOAD CURRENT	9.4 A
13. STARTING CURRENT AT RATED VOLTAGE	47.0 A
14. MINIMUM STATING VOLTAGE	198 V
15. EFFICIENCY AT 100% RAGED LOAD	72.0%
16. POWER FACTOR AT 100% RATED LOAD	70.0%
17. STARTING TORQUE	238%
18. TYPE OF ENCLOSURE	전폐형
19. TYPE OF BEARING	PL : 6008DD OPL : 6207ZZ
20. MOUNTING	VERTICAL
21. MAXIMUM AMBIENT TEMPURE	40°C
22. BEARING LUBRICATION	GREASE
23. STARTING METHOD	FULL VOLTAGE

SCHEDULE OF TECHNICAL DATA

1. SERVICE	HOISTING
2. MANUFACTURE	DAESAN INOTEC INC.
3. MOTOR MODEL NO.	DSAI - 1S - 380
4. RATED POWER	1.8 KW x 4 P
5. RATED VOLTAGE AND FREQUENCY	380 V 60 HZ
6. MOTOR TYPE	SQUIRREL CAGE ROTOR YPE
7. RATING	30 MIN
8. LOCATION	IN-DOOR , OUT-DOOR
9. INSULATION CLASS	B
10. DESING TEMPERATURE RISE (BY RESISTANCE)	80°C
11. FULL LOAD SPEED	1740 RPM
12. FULL LOAD CURRENT	5.5 A
13. STARTING CURRENT AT RATED VOLTAGE	26.8 A
14. MINIMUM STATING VOLTAGE	342 V
15. EFFICIENCY AT 100% RAGED LOAD	72.5%
16. POWER FACTOR AT 100% RATED LOAD	68.8%
17. STARTING TORQUE	243%
18. TYPE OF ENCLOSURE	전폐형
19. TYPE OF BEARING	PL : 6008DD OPL : 6207ZZ
20. MOUNTING	VERTICAL
21. MAXIMUM AMBIENT TEMPURE	40°C
22. BEARING LUBRICATION	GREASE
23. STARTING METHOD	FULL VOLTAGE

SCHEDULE OF TECHNICAL DATA

1. SERVICE	HOISTING
2. MANUFACTURE	DAESAN INOTEC INC.
3. MOTOR MODEL NO.	DSAI - 1S - 440
4. RATED POWER	1.8 KW x 4 P
5. RATED VOLTAGE AND FREQUENCY	440 V 60 HZ
6. MOTOR TYPE	SQUIRREL CAGE ROTOR YPE
7. RATING	30 MIN
8. LOCATION	IN-DOOR , OUT-DOOR
9. INSULATION CLASS	B
10. DESING TEMPERATURE RISE (BY RESISTANCE)	80°C
11. FULL LOAD SPEED	1740 RPM
12. FULL LOAD CURRENT	4.7 A
13. STARTING CURRENT AT RATED VOLTAGE	22.8 A
14. MINIMUM STATING VOLTAGE	396 V
15. EFFICIENCY AT 100% RAGED LOAD	71.9%
16. POWER FACTOR AT 100% RATED LOAD	69.8%
17. STARTING TORQUE	245%
18. TYPE OF ENCLOSURE	전폐형
19. TYPE OF BEARING	PL : 6008DD OPL : 6207ZZ
20. MOUNTING	VERTICAL
21. MAXIMUM AMBIENT TEMPURE	40°C
22. BEARING LUBRICATION	GREASE
23. STARTING METHOD	FULL VOLTAGE

SCHEDULE OF TECHNICAL DATA

1. SERVICE	TRAVERSING
2. MANUFACTURE	DAESAN INOTEC INC.
3. MOTOR MODEL NO.	MT - 1 - 220
4. RATED POWER	0.4 KW x 6 P
5. RATED VOLTAGE AND FREQUENCY	220 V 60 HZ
6. MOTOR TYPE	SQUIRREL CAGE ROTOR YPE
7. RATING	30 MIN
8. LOCATION	IN-DOOR
9. INSULATION CLASS	B
10. DESING TEMPERATURE RISE (BY RESISTANCE)	100°C
11. FULL LOAD SPEED	1140 RPM
12. FULL LOAD CURRENT	3.3 A
13. STARTING CURRENT AT RATED VOLTAGE	13.9 A
14. MINIMUM STATING VOLTAGE	198V
15. EFFICIENCY AT 100% RAGED LOAD	57.5%
16. POWER FACTOR AT 100% RATED LOAD	54.5%
17. STARTING TORQUE	249%
18. TYPE OF ENCLOSURE	전폐형
19. TYPE OF BEARING	PL : 6202DD OPL : 6204ZZ
20. MOUNTING	VERTICAL
21. MAXIMUM AMBIENT TEMPURE	40°C
22. BEARING LUBRICATION	GREASE
23. STARTING METHOD	FULL VOLTAGE

SCHEDULE OF TECHNICAL DATA

1. SERVICE	TRAVERSING
2. MANUFACTURE	DAESAN INOTEC INC.
3. MOTOR MODEL NO.	MT - 1 - 380
4. RATED POWER	0.4 KW x 6 P
5. RATED VOLTAGE AND FREQUENCY	380 V 60 HZ
6. MOTOR TYPE	SQUIRREL CAGE ROTOR YPE
7. RATING	30 MIN
8. LOCATION	IN-DOOR
9. INSULATION CLASS	B
10. DESING TEMPERATURE RISE (BY RESISTANCE)	100°C
11. FULL LOAD SPEED	1140 RPM
12. FULL LOAD CURRENT	1.7 A
13. STARTING CURRENT AT RATED VOLTAGE	9.2 A
14. MINIMUM STATING VOLTAGE	342V
15. EFFICIENCY AT 100% RAGED LOAD	53.0%
16. POWER FACTOR AT 100% RATED LOAD	51.0%
17. STARTING TORQUE	249%
18. TYPE OF ENCLOSURE	전폐형
19. TYPE OF BEARING	PL : 6202DD OPL : 6204ZZ
20. MOUNTING	VERTICAL
21. MAXIMUM AMBIENT TEMPURE	40°C
22. BEARING LUBRICATION	GREASE
23. STARTING METHOD	FULL VOLTAGE

SCHEDULE OF TECHNICAL DATA

1. SERVICE	TRAVERSING
2. MANUFACTURE	DAESAN INOTEC INC.
3. MOTOR MODEL NO.	MT - 1 - 440
4. RATED POWER	0.4 KW x 6 P
5. RATED VOLTAGE AND FREQUENCY	440 V 60 HZ
6. MOTOR TYPE	SQUIRREL CAGE ROTOR YPE
7. RATING	30 MIN
8. LOCATION	IN-DOOR
9. INSULATION CLASS	B
10. DESING TEMPERATURE RISE (BY RESISTANCE)	100°C
11. FULL LOAD SPEED	1140 RPM
12. FULL LOAD CURRENT	1.5 A
13. STARTING CURRENT AT RATED VOLTAGE	9.2 A
14. MINIMUM STATING VOLTAGE	396V
15. EFFICIENCY AT 100% RAGED LOAD	55.3%
16. POWER FACTOR AT 100% RATED LOAD	57.2%
17. STARTING TORQUE	249%
18. TYPE OF ENCLOSURE	전폐형
19. TYPE OF BEARING	PL : 6202DD OPL : 6204ZZ
20. MOUNTING	VERTICAL
21. MAXIMUM AMBIENT TEMPURE	40°C
22. BEARING LUBRICATION	GREASE
23. STARTING METHOD	FULL VOLTAGE

I-beam calculation sheets

	I-150x75x5.5/9.5	I-200x100x7/10			I-250x125x7.5/12.5				I-300x150x10/18	I-400x150x10/18		I-600x190x13/25
	1TON	1TON	2(1.9)TON	3TON	1TON	2(1.9)TON	3TON	5TON	2(1.9)TON	3TON	5TON	5TON
SPAN L=Cm	300	400	300	250	600	400	400	250	650	700	400	1000
I _x (Cm ⁴)	819	2170			5180				9480	24100		98400
I _y (Cm ⁴)	57.5	138			337				588	864		2460
z _x (Cm ³)	109	217			414				632	1200		3280
z _y (Cm ³)	15.3	27.7			53.9				78.4	115		259
S ₁ (Kg·Cm ²)	883	604	863(821)	1124	503	619(589)	683	908	507(484)	588	737	530
δ(Cm)	0.35	0.32	0.26	0.24	0.48	0.26	0.39	0.16	0.48	0.48	0.26	0.59
δ/L	1/854	1/1250	1/1158	1/1030	1/1243	1/1523	1/1025	1/1623	1/1369	1/1470	1/1526	1/1675

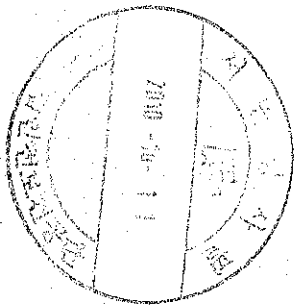

EC Declaration of Conformity

We hereby declare that the following product is in conformity with the essential health and safety requirements of the following EC Directive:

Product : AC Motor
Model : DSMI-12
Manufacture : INOTEC IND. CO., LTD
Address : Siwa Ind. Site 3RA 820, Jungwang-Dong 1370-4
Shheung Gyonggi-Do, Korea
Rated input voltage : AC 220V / 380V / 440V
Rated frequency : 50/60 Hz
Rated input current : 3.3A/1.67A/1.45A
Applicable EU Directive : Low Voltage Directive (73/23/EEC)
EMC Directive (89/336/EEC)

This product is designed and manufactured in accordance with the following standards

Applicable standards : IEC 60034-1: 2004
IEC 60034-11:2004

Year of CE Marking : 2005-12-27

Authorized signature :

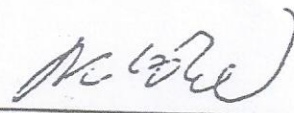

Name / Title of signatory :



/ President

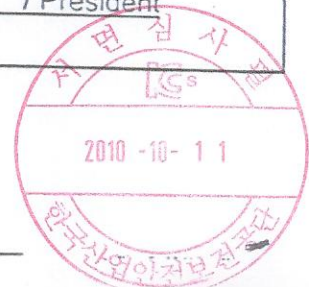

DAESAN

INOTEC IND. CO., LTD

EC Declaration of Conformity

We hereby declare that the following product is in conformity with the essential health and safety requirements of the following EC Directive:

Product : AC Motor
Model : DSAI-1S
Manufacture : INOTEC IND. CO., LTD
Address : Siwa Ind. Site 3RA 820, Jungwang-Dong 1370-4
Shheung Gyonggi-Do, Korea
Rated input voltage : AC 220V / 380V / 440V
Rated frequency : 50/60 Hz
Rated input current : 9.2A/4.91A/4.24A
Applicable EU Directive : Low Voltage Directive (73/23/EEC)

This product is designed and manufactured in accordance with the following standards

Applicable standards : IEC 60034-1: 2004
IEC 60034-11:2004

Year of CE Marking : 2005-12-27

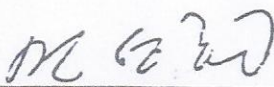
Authorized signature : 

Name / Title of signatory : 김성권 / President

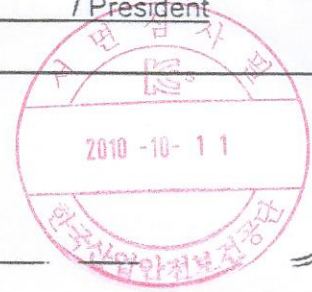

호이스트 스위치

전자 조작용 개폐 스위치 (HOIST SWITCH)

- 전동 HOIST조작용으로 현수식 놀름버튼형 개폐기입니다.
- 방수형의 구조이며 외곽케이스는 기계적 강도 및 전기적 특성이 우수한 수지를 사용하여 가볍고 견고하게 설계되었습니다.
- 스위치 자체에 전원 단절용으로 주회로를 개폐할 수 있는 구조로 되어 있습니다.
- 접점 부분은 1단(1a)이 기본이며, 전동기 속도 제어용에 필요한 2단 접점이 있어 필요 부분에 부착 사용할 수 있도록 설계되어 있습니다.
- 풍부한 버튼 문자판이 준비되어 있어 용도에 맞추어 선택 사용이 용이합니다.
- 소형 및 경량으로 설계되어 경제적입니다.
- 걸고리가 장착되어 사용이 편리합니다.



■ 구조

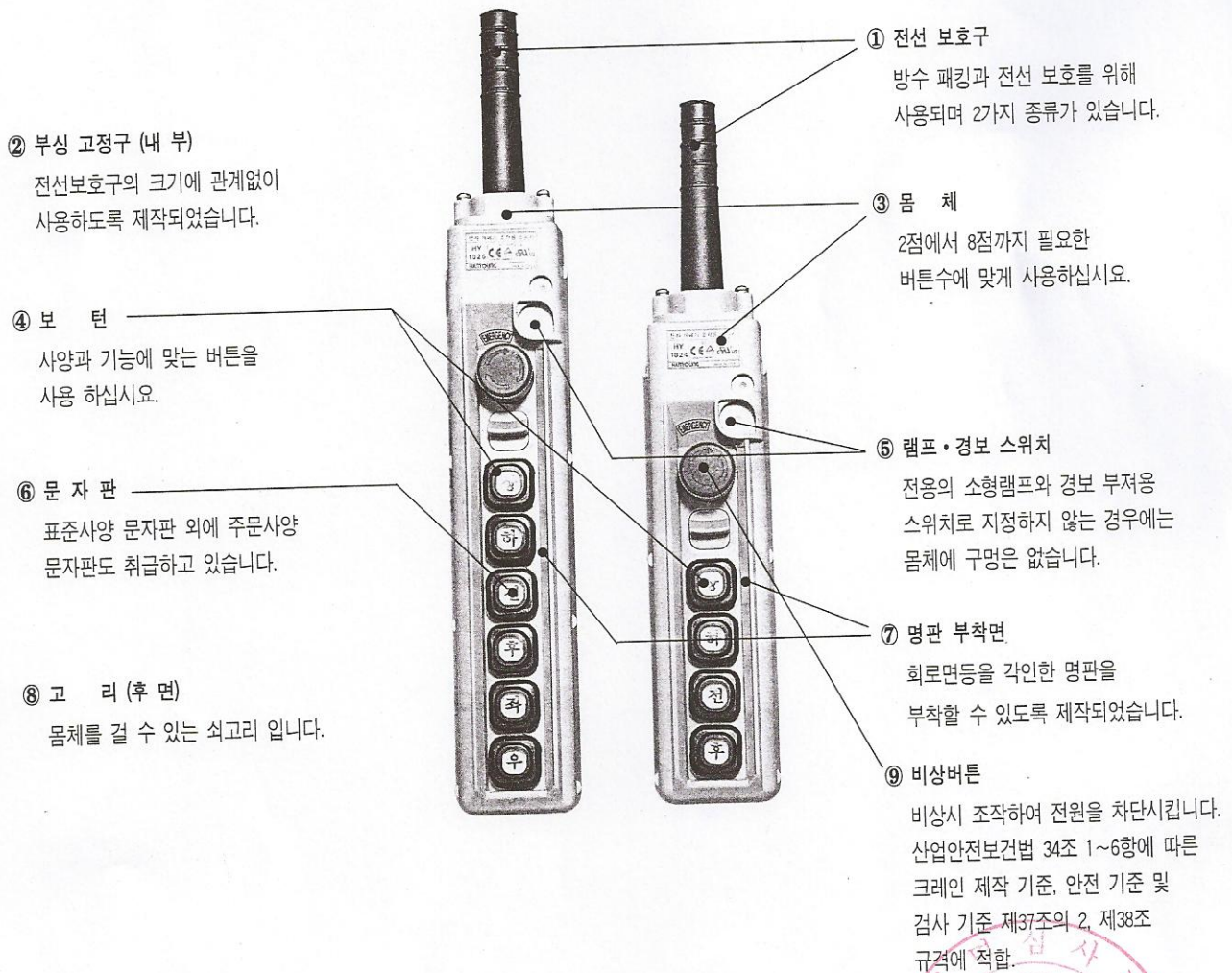

호이스트 스위치

HY-1022 SB

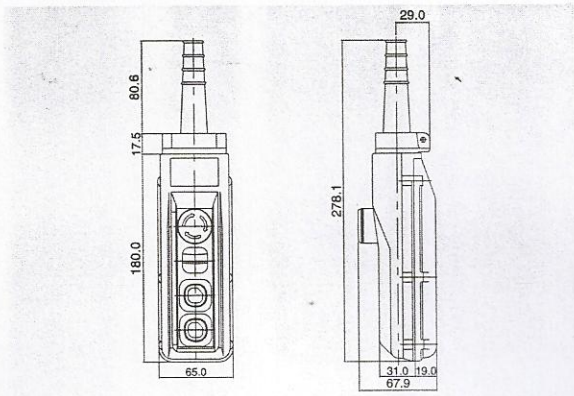

HY-1024 AB

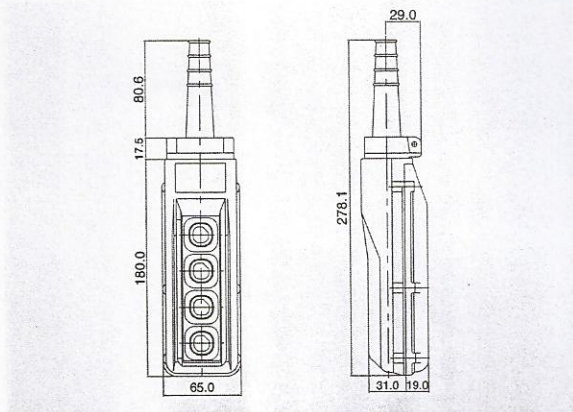

HY-1024 BB

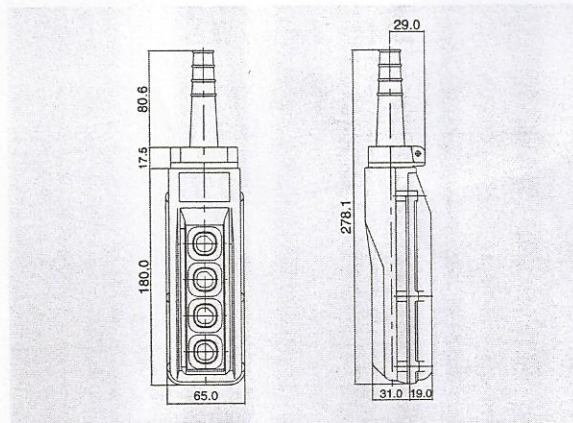
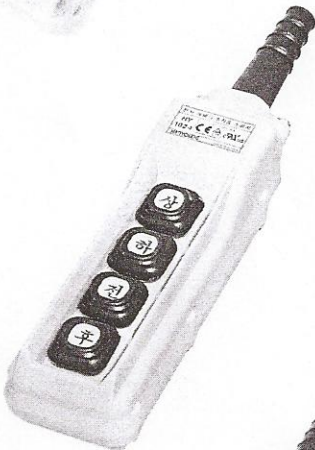

HY-1024SBB

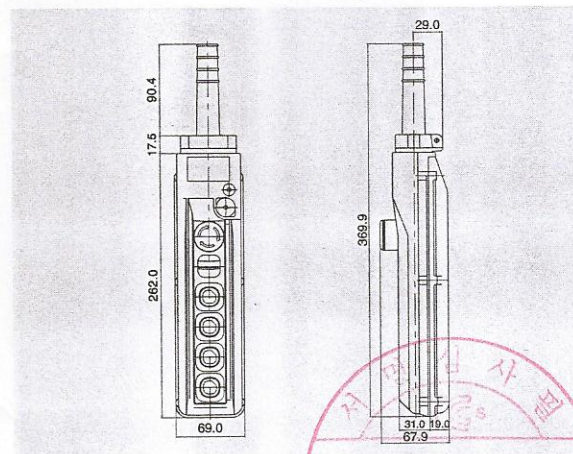
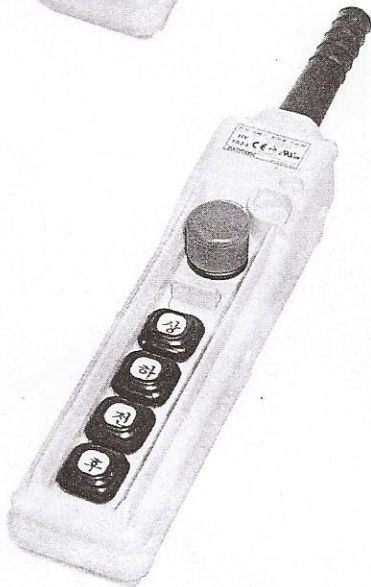

개 페스위 처
조 작 용

시그 피
라 이 트
모 델 | 부
기 호

호이스트 스위치

HY-1026 ABB

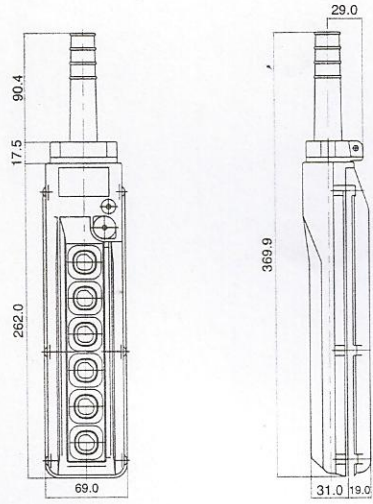
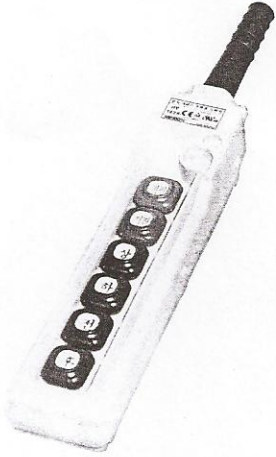

HY-1026 BBB

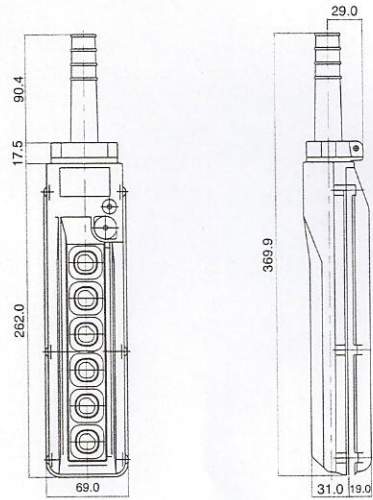
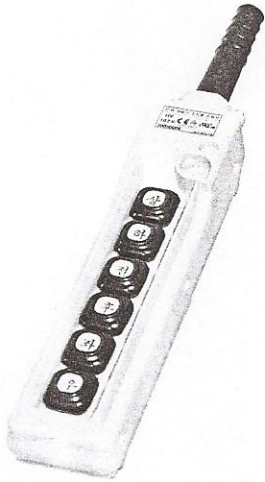

HY-1026 SBBB

