



제 2013 - 58525 호

안 전 인 증 서

(사업장명)

(주)대산이노텍

(소재지)

(314-821)충남 공주시 정안면 사현리523

위 사업장에서 제조하는 아래의 품목이 산업안전보건법 제34조 및 같은 법 시행규칙 제58조의4제4항에 따른 안전인증 심사 결과 안전·보건기준에 적합하므로 안전인증표시의 사용을 인증합니다.

_____ 품 목 _____
호이스트

_____ 형식,모델(용량,등급)/인증번호 _____
DSHM-1.9W (1.9Ton) /13-AG2AC-01677

_____ 인 증 기 준 _____
고용노동부 고시 제2012 - 33호 (위험기계,기구 의무안전인증 고시)

_____ 인 증 조 건 _____
인증유효기간 :

2013년 05월 30일

한국산업안전보건공단이사장



TECHNICAL SPECIFICATION

DESCRIPTION		1.9 TON MONORAIL HOIST		
TYPE		DSHM-1.9W MONORAIL TYPE		
HOISTING LOAD		1.9 TON		
TESTING LOAD		2.375 TON		
LIFT		50 M		
SPEED & MOTOR	HOISTING	60 Hz	4.1	1.8KW × 4P
		50 Hz	3.4	
	TRAVERSING	60 Hz	15,22	0.4KW × 4P/6P
		50 Hz	12,15	
BRAKE SYSTEM	HOISTING	D.C MAGNET DISC BRAKE		
	TRAVERSING	MECHANICAL BRAKE		
ELECTRIC SPECIFICATION	POWER SOURCE	AC 3Ø 60/50Hz 220V, 380V, 440V, 480V.		
	CONTROL SOURCE	AC 1Ø 50/60Hz 110V		
	LIMIT SWITCH	TWO STEP LIMIT SWITCH		
	OVER LOAD LIMITER	ELECTRICAL TYPE.		
	EM. STOP DEVICE	EMERGENCY STOP BUTTON		
LOAD CHAIN	Ø 7.1 x 21			
TRAVERSING POWER SYSTEM	TROLLEY BAR OR FESTOON TYPE			
MAX AMBIENT TEMPERATURE	40°C			
RATING	30 MIN			
RATED DUTY	40%ED, ED = $\frac{\text{motor operation period(min) at maximum duty per hour}}{60\text{min}}$			
AREA CLASSIFICATION	INDOOR			
CONTROL METHOD	BY PENDANT PUSH BUTTON S/W			
PAINTING COLOR	MUN SELL NO EX8816D YELLOW			

NO	DESCRIPTION	MAT'L	Q'TY	(kg)	REMARKS

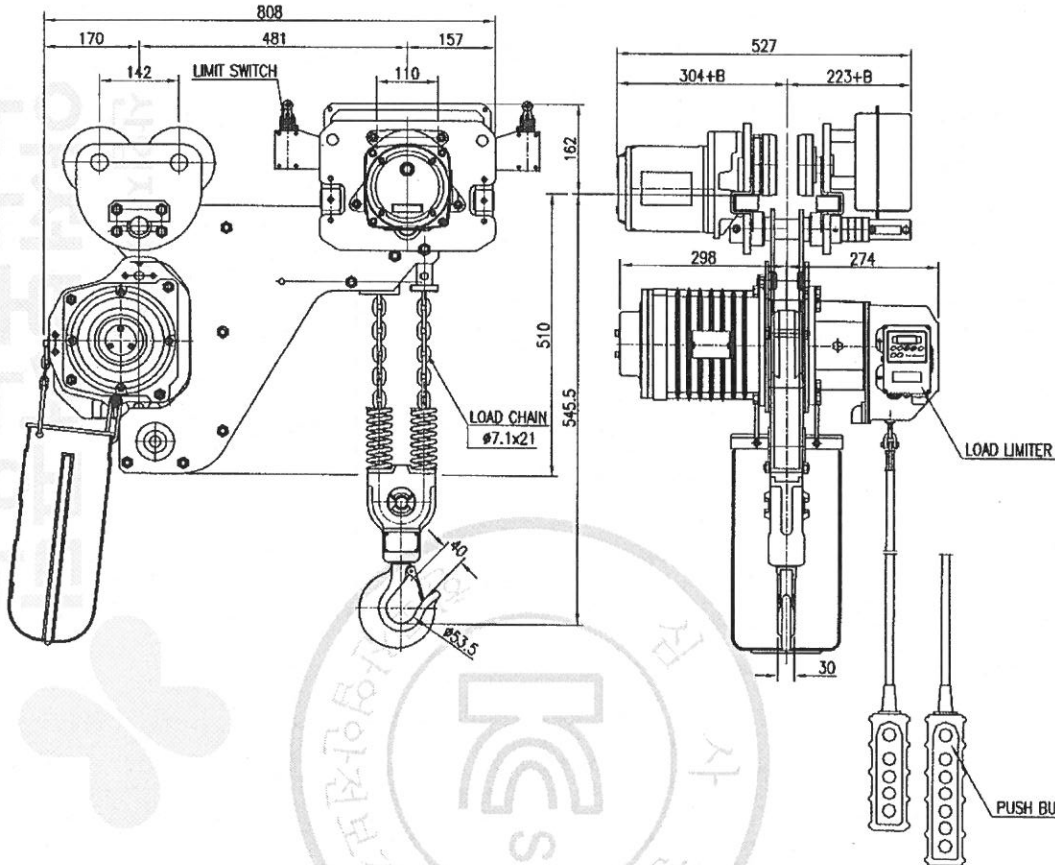

SPECIFICATION		
HOISTING LOAD	1.9	TON
TESTING LOAD	2.375	TON
LIFTING HEIGHT	50	M
HOISTING	SPEED	4.1 M/MIN
	MOTOR	1.8 KW x 4P x 1 SET
TRAVERSING	SPEED	15/22 M/MIN
	MOTOR	0.4 KW x 4/6P x 1SET
POWER SUPPLY	AC 220, 380, 440, 480V x 3φ x 60 Hz	
OPERATING METHOD	P.B type ON . FL	
WEIGHT	279 KG	
I-BEAM SIZE	100-150	

- * β는 BEAM폭 치수임.
- * ROLLER DIA : Ø110
- * LIMIT SWITCH : OPTION
- * 본 도면은 I-BEAM 100MM 기준임.

TITLE DSHAM-1.9W CHAIN HOIST				PROJECTION	
WORK NO	WORK NAME				
				SCALE	Q'TY
				1/1	1
DRAWN	CHECKED	REVIEWED	APPROVED	DRAWING NO	
YOO.M.R	-	LEE. H.J	Y.K	DSHM20W002	
2012.11.27	-	2012.11.27	2012.11.27		
DAESAN INoTEC IND. CO., LTD.					

REV.NO	DATE	REVISION DESCRIPTION	DRAWN	CHECKED	APPROVED

192.168.0.11 / 2018-05-14 11:57:07

KOREA OCCUPATIONAL SAFETY & HEALTH AGENCY

불법복제 및 배포금지

10 9 8 7 6 5 4 3 2 1

NO	COMMODITY	CAPACITY	MODEL NO	MAKER

ELECTRICAL DRAWING LIST	
DRAWING NO.	DIAGRAM LIST
DSHM1000	ELECTRICAL DRAWING LIST
DSHM1001	ELECTRIC ELEMENTARY DIAGRAM SYMBOL LIST
DSHM1002	ELECTRIC HOIST EQUIPMENT BOARD ASS'Y DRAWING (DSHM-1S,1.9W,2W/220[V],380[V],440[V])
DSHM1003	ELECTRIC HOIST EQUIPMENT BOARD ASS'Y DRAWING (DSHM-2S,1.9S, 3W,5W/220[V],380[V],440[V])
DSHM1004	ELECTRIC TROLLEY BOARD ASS'Y DRAWING (DSHM-1S,1.9W,2W,1.9S,2S,3W,5W/220[V],380[V],440[V])
DSHM1005	INTERLOCK LIST (DSHM-1S,1.9W,2W,1.9S,2S,3W,5W/220[V],380[V],440[V])
DSHM1006	접지도면 (DSHM-1S,1.9W,2W/220[V],380[V],440[V])
DSHM1007	접지도면 (DSHM-1.9S,2S,3W,5W/220[V],380[V],440[V])
DSHM1008	사용전선도면 (DSHM-1S,1.9W,2W/220[V],380[V],440[V])
DSHM1009	사용전선도면 (DSHM-1.9S,2S,3W,5W/220[V],380[V],440[V])
DSHM0001	CONTROL CIRCUIT DIAGRAM (DSHM-1S,1.9W,2W)
DSHM0002	CONTROL CIRCUIT DIAGRAM (DSHM-1.9S,2S,3W,5W)
DSHM0003	POWER CIRCUIT DIAGRAM (DSHM-1S,1.9W,2W/220[V],380[V],440[V])
DSHM0004	POWER CIRCUIT DIAGRAM (DSHM-1.9S,2S/220[V],380[V],440[V])
DSHM0005	POWER CIRCUIT DIAGRAM (DSHM-3W,5W/220[V],380[V],440[V])
	기타 자료 (PART LIST, 감전방지, 접지내용 CHART, 접지 계통도, 전선 허용전류, 차단기 선정 표)

KOREA OCCUPATIONAL SAFETY & HEALTH AGENCY
 안전보건공단
 한국산업안전보건공단

192.168.0.11 / 2013-05-14 11:57:07

물범복제 및 배포금지

REV. NO	DATE	REVISION DESCRIPTION	DRAWN	CHECKED	APPROVED

TITLE				PROJECTION
CIRCUIT DIAGRAM OF DSHM				
WORD NO	WORK NAME			
	ELECTRIC DRAWING LIST			SCALE Q'TY
	DSHM-1S,1.9W,2W,1.9S,2S,3W,5W			
DRAWN	CHECKED	REVIEWED	APPROVED	DRAWING NO
E.D			Y.K	DSHM1000
2013.04.03			2013.04.03	
DAESAN INoTECIND. CO., LTD.				

10 9 8 7 6 5 4 3 2 1

10 9 8 7 6 5 4 3 2 1

NO	COMMODITY	CAPACITY	MODEL NO	MAKER

ELECTRIC ELEMENTARY DIAGRAM SYBOL LIST

항목	기호	약호	명칭	항목	기호	약호	명칭
1			WIRE	22		M302	WEST MAGNET CONTACT 주접점
2			WIRE CONNECTED	23		M101	UP MAGNET CONTACT 보조접점 a접점
3			TERMINAL	24		M102	DOWN MAGNET CONTACT 보조접점 a접점
4			접지	25		M101	UP MAGNET CONTACT 보조접점 b접점
5			전원입력	26		M102	DOWN MAGNET CONTACT 보조접점 b접점
6			NONE FUSE BREAKER	27		M301	EAST MAGNET CONTACT 보조접점 b접점
7			FUSE	28		M302	WEST MAGNET CONTACT 보조접점 b접점
8			비상스위치	29		UPPER L/S	UP LIMIT SWITCH b접점
9			PUSH BUTTON SWITCH a접점	30		LOWER L/S	DOWN LIMIT SWITCH b접점
10			TRANSFORMER	31		EAST L/S	횡행 LIMIT SWITCH b접점
11			정류기	32		WEST L/S	횡행 LIMIT SWITCH b접점
12			CURRENT TRANSFORMER	33		TP1	관상용 MOTOR 열동계전기 b접점
13			관상용 MOTOR	34		TP2	횡행 MOTOR 열동계전기 b접점
14			횡행 MOTOR	35		SOL	SOLENOID TYPE DC MAGNET BRAKE COIL
15			UP MAGNET CONTACTOR	36			MAIN MAGNETIC CONTACTOR
16			DOWN MAGNET CONTACTOR	37		M001	MAIN MAGNETIC CONTACTOR 주접점
17			EAST MAGNET CONTACTOR				
18			WEST MAGNET CONTACTOR				
19		M101	UP MAGNET CONTACT 주접점				
20		M102	DOWN MAGNET CONTACT 주접점				
21		M301	EAST MAGNET CONTACT 주접점				

KOREA OCCUPATIONAL SAFETY & HEALTH AGENCY



물범복제 및 배포금지

TITLE				CIRCUIT DIAGRAM OF DSHM		PROJECTION	
WORD NO	WORK NAME			DIAGRAM SYMBOL LIST		SCALE	QTY
	DSHM-1S,19W,2W,19S,2S,3W,5W						
DRAWN	CHECKED	REVIEWED	APPROVED	DRAWING NO			
E.D			Y.K	DSH-M1001			
2013.04.03			2013.04.03				
DAESAN INOTECIND. CO., LTD.							

REV. NO	DATE	REVISION DESCRIPTION	DRAWN	CHECKED	APPROVED
10					
9					
8					
7					
6					
5					
4					
3					
2					
1					

192.168.0.11 / 2013-05-14 11:57:07

192.168.0.11 / 2013-05-14 11:57:07

KOREA OCCUPATIONAL SAFETY & HEALTH AGENCY

안전보건공단
안전보건연구원

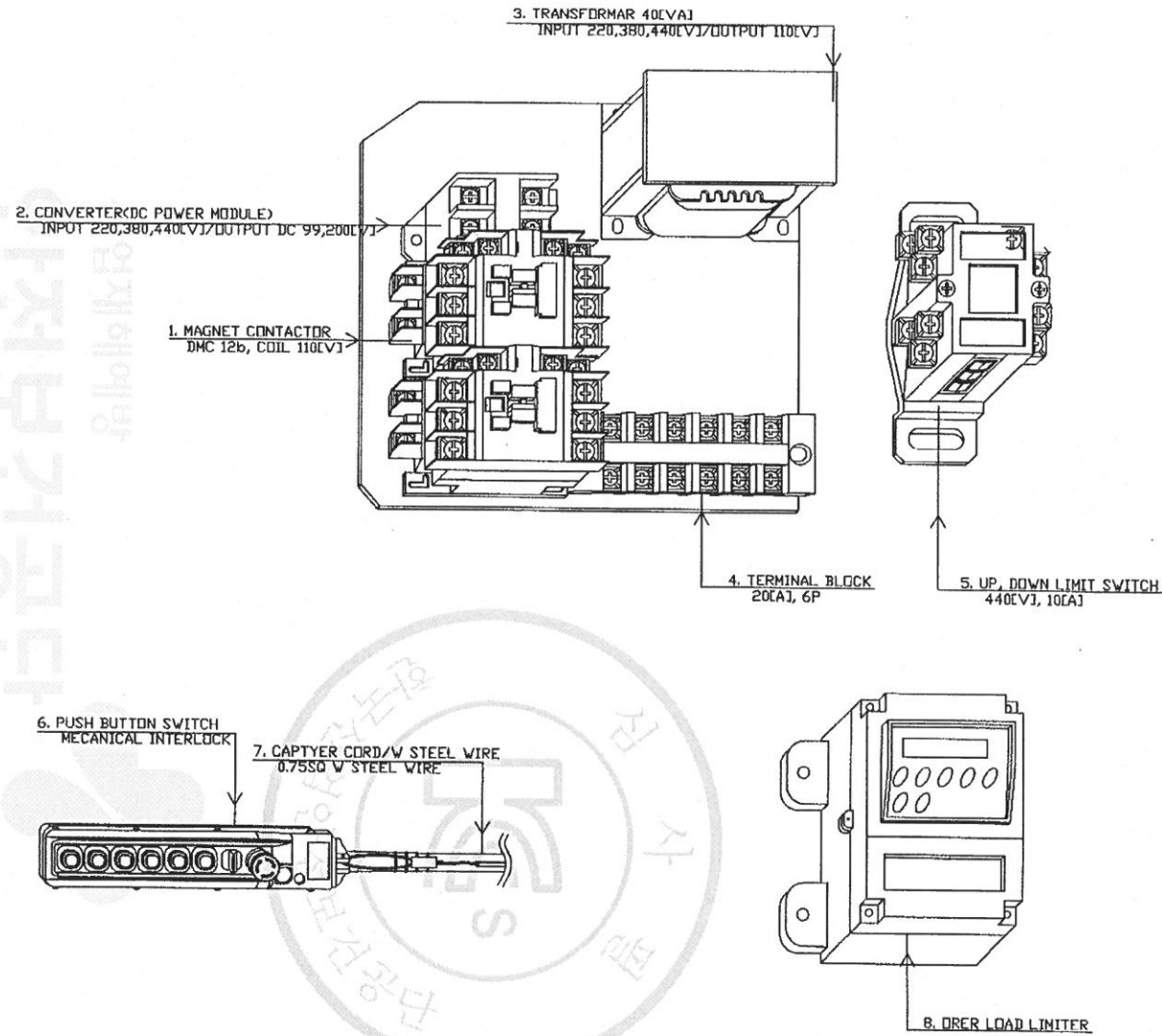
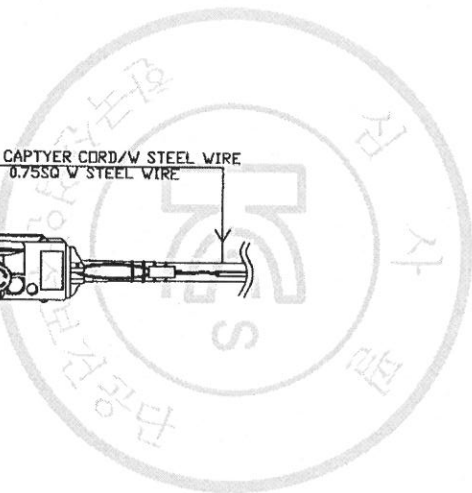

NO	COMMODITY	CAPACITY	MODEL NO	MAKER
1	Magnetic contactor	Coil 110V	DMC-12b	Dong-a
2	Rectifier	D.C 99-200V	SR-304	영호Eng
3	Transformer	220,380,440V/110V	DSAC-T	광일전자
4	Terminal Block	20A 6P	TB1-02006	KACON
5	CAM Switch	10A 1P	HY-SGS-S	한양나스
6	Magnetic contactor	250V 6A	SH-1022SBB	한양나스
			SH-1024SBB	
7	Captyer Cord/w Steel Wier	0.75SQ#5C	-	광일전자
		0.75SQ#7C		
		0.75SQ#9C		
8	Load Limiter	70TIN 이하	JDL-100	영호Eng

TITLE				PROJECTION	
CIRCUIT DIAGRAM OF DSHM					
WORD NO	WORK NAME			SCALE	Q'TY
	EQUIPMENT BOARD ASS'Y DRAWING				
	DSHM-1S.1.9W,2W				
DRAWN	CHECKED	REVIEWED	APPROVED	DRAWING NO	
E.D			Y.K	DSH-M1002	
2013.04.03			2013.04.03		
DAESAN INoTECIND. CO., LTD.					

REV. NO	DATE	REVISION DESCRIPTION	DRAWN	CHECKED	APPROVED
10					
9					
8					
7					
6					
5					
4					
3					
2					
1					

물범복제 및 배포금지

192.168.0.11 / 2013-05-14 11:57:07

KOREA OCCUPATIONAL SAFETY & HEALTH AGENCY

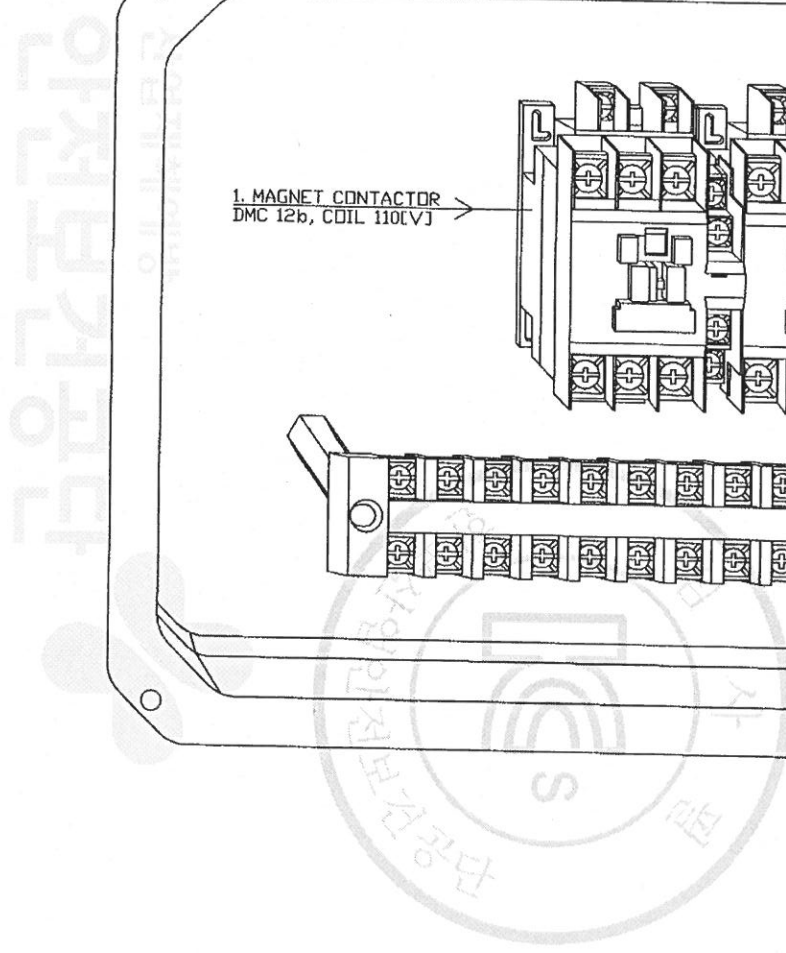

NO	COMMODITY	CAPACITY	MODEL NO	MAKER
1	Magnetic contactor	CDIL 110V	DMC-22b	Dong-a
2	Terminal Block	20A 15P	TBI-02006	KADEN

TITLE				PROJECTION	
CIRCUIT DIAGRAM OF DSHM					
WORD NO	WORK NAME			SCALE	Q'TY
	ELECTRIC TROLLEY BOARD ASSY DRAWING				
	DSHM-1S,1.9W,2W,1.9S,2S,3W,5W				
DRAWN	CHECKED	REVIEWED	APPROVED	DRAWING NO	
E.D			Y.K	DSHM1004	
2013.04.03			2013.04.03		
DAESAN INOTECIND. CO., LTD.					

REV. NO	DATE	REVISION DESCRIPTION	DRAWN	CHECKED	APPROVED
	10				
	9				
	8				
	7				
	6				
	5				
	4				
	3				
	2				
	1				

물범복제 및 배포금지

192.168.0.11 / 2013-05-14 11:57:07

KOREA OCCUPATIONAL SAFETY & HEALTH AGENCY

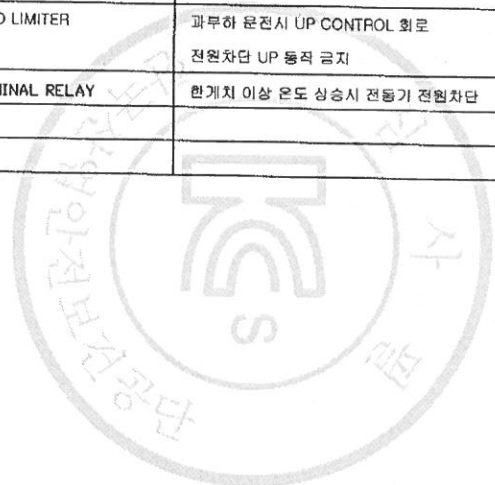

물범복제 및 배포금지

NO	COMMODITY	CAPACITY	MODEL NO	MAKER

INTERLOCK LIST

순번	기호/약어	명 칭	역 할	차 단 범 위	차 단 방 법	비 고
1	E/M	비상정지 스위치	비상시 전원차단	전동기 및 제어회로의 전원차단	마크네트 스위치 주점접 OPEN	
2	L/S UP	UP 리미트 스위치	한계치 이상 상승시 전동기 전원차단	전동기 전원차단	마크네트 스위치 주점접 OPEN	
3	L/S DOWN	DOWN 리미트 스위치	한계치 이상 하강시 전동기 전원차단	전동기 전원차단	마크네트 스위치 주점접 OPEN	
4	L/S EAST	RIGHT 리미트 스위치	한계치 이상 RIGHT 이동시 전동기 전원차단	전동기 전원차단	마크네트 스위치 주점접 OPEN	OPTION
5	L/S WEST	LEFT 리미트 스위치	한계치 이상 LEFT 이동시 전동기 전원차단	전동기 전원차단	마크네트 스위치 주점접 OPEN	OPTION
6	M101	UP M/C 보조점접 b점접	UP 동작시 DOWN 동작 금지	UP/DOWN 동시투입 금지	M/C 보조점접 b 점접 OPEN	
7	M102	DOWN M/C 보조점접 b점접	DOWN 동작시 UP 동작 금지	UP/DOWN 동시투입 금지	M/C 보조점접 b 점접 OPEN	
8	M301	EAST M/C 보조점접 b점접	RIGHT 동작시 LEFT 동작 금지	UP/DOWN 동시투입 금지	M/C 보조점접 b 점접 OPEN	
9	M302	WEST M/C 보조점접 b점접	LEFT 동작시 RIGHT 동작 금지	UP/DOWN 동시투입 금지	M/C 보조점접 b 점접 OPEN	
10	역상방지기	역상방지기	UP/DOWN 역상결선시 CONTROL회로 전원차단 UP/DOWN 동작 금지	UP/DOWN 동시투입 금지	내부 RELAY 보조점접 b 점접 OPEN	
11	LOAD LIMITER	LOAD LIMITER	과부하 운전시 UP CONTROL 회로 전원차단 UP 동작 금지	과부하 운전 금지	UP CONTROL회로 전원차단	
12	TP	TERMINAL RELAY	한계치 이상 온도 상승시 전동기 전원차단	전동기 전원차단	TP 내부점접 OPEN	전동기 내장

REV. NO	DATE	REVISION DESCRIPTION	DRAWN	CHECKED	APPROVED

TITLE				PROJECTION	
CIRCUIT DIAGRAM OF DSHM					
WORD NO	WORK NAME			SCALE	Q'TY
	INTERLOCK LIST				
	DSHM-1S,1.9W,2W,1.9S,2S,3W,5W				
DRAWN	CHECKED	REVIEWED	APPROVED	DRAWING NO	
E.D			Y.K	DSHM1005	
2013.04.03			2013.04.03		
DAESAN INOTECIND. CO., LTD.					

192.168.0.11 / 2013-05-14 11:57:07

KOREA OCCUPATIONAL SAFETY & HEALTH AGENCY

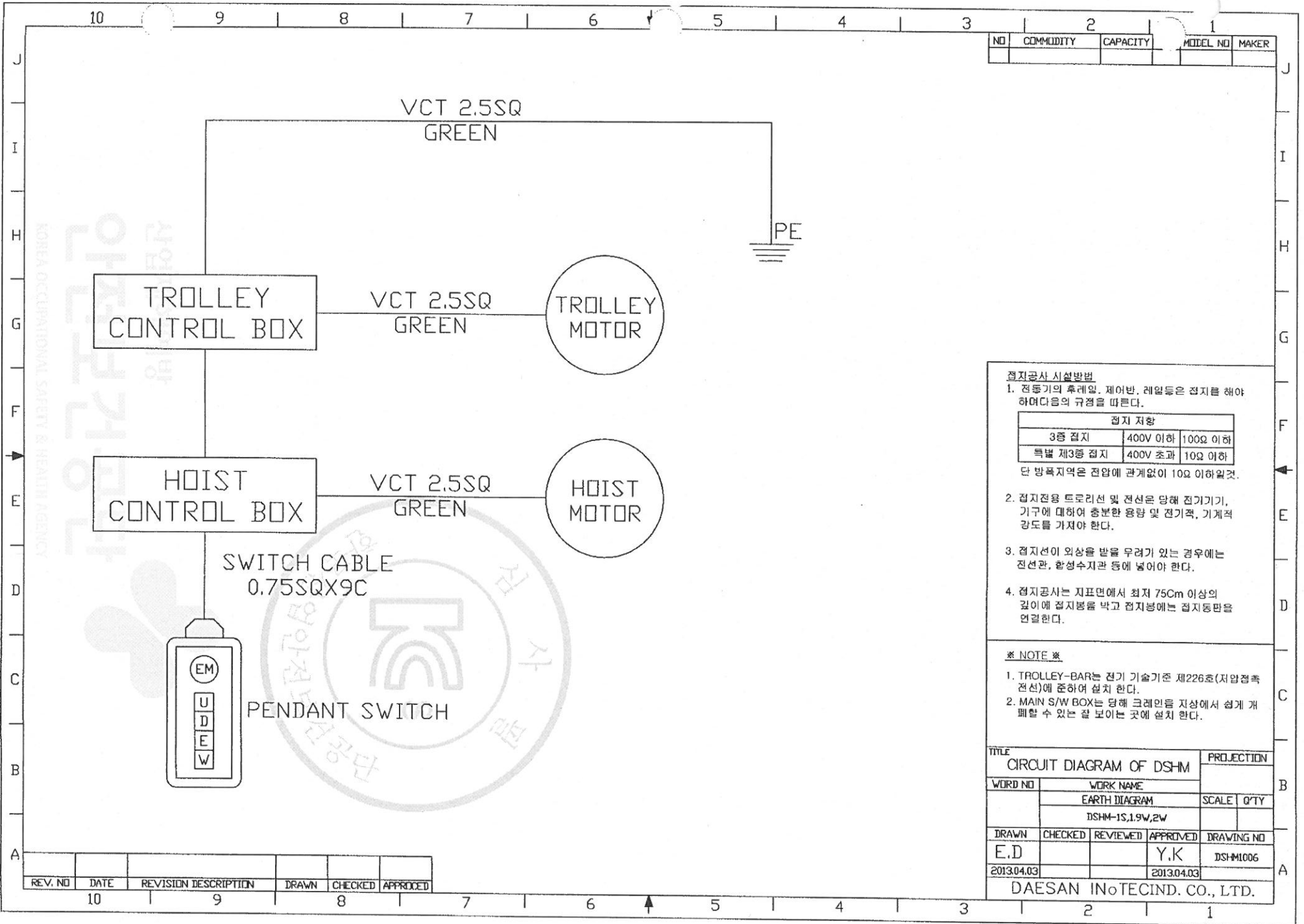

NO	COMMODITY	CAPACITY	MODEL NO	MAKER

접지공사 시설행법
 1. 전동기의 후레일, 제어반, 레일등은 접지를 해야 하며다음의 규정을 따른다.

접지 저항		
3중 접지	400V 이하	100Ω 이하
특별 제3중 접지	400V 초과	10Ω 이하

- 단 방폭지역은 전압에 관계없이 10Ω 이하일것.
2. 접지전용 드로리선 및 전선은 양해 전기기기, 기구에 대하여 충분한 용량 및 견기력, 기계적 강도를 가져야 한다.
 3. 접지선이 외상을 받을 우려가 있는 경우에는 전선관, 합성수지관 등에 넣어야 한다.
 4. 접지공사는 지표면에서 최저 75Cm 이상의 길이에 접지봉을 박고 접지봉에는 접지동판을 연결한다.

※ NOTE ※

1. TROLLEY-BAR는 전기 기술기준 제226호(저압점속 전선)에 준하여 설치 한다.
2. MAIN S/W BOX는 당해 크레인용 지상에서 쉽게 개폐할 수 있는 곳 보아는 곳에 설치 한다.

TITLE				PROJECTION	
CIRCUIT DIAGRAM OF DSHM					
WORD NO	WORK NAME				
	EARTH DIAGRAM			SCALE	Q'TY
	DSHM-1S,1.9W,2W				
DRAWN	CHECKED	REVIEWED	APPROVED	DRAWING NO	
E.D			Y.K	DSHM1006	
2013.04.03			2013.04.03		
DAESAN INoTECIND. CO., LTD.					

별첨복제 및 배포금지

10 9 8 7 6 5 4 3 2 1

NO	COMMODITY	CAPACITY	MODEL NO	MAKER

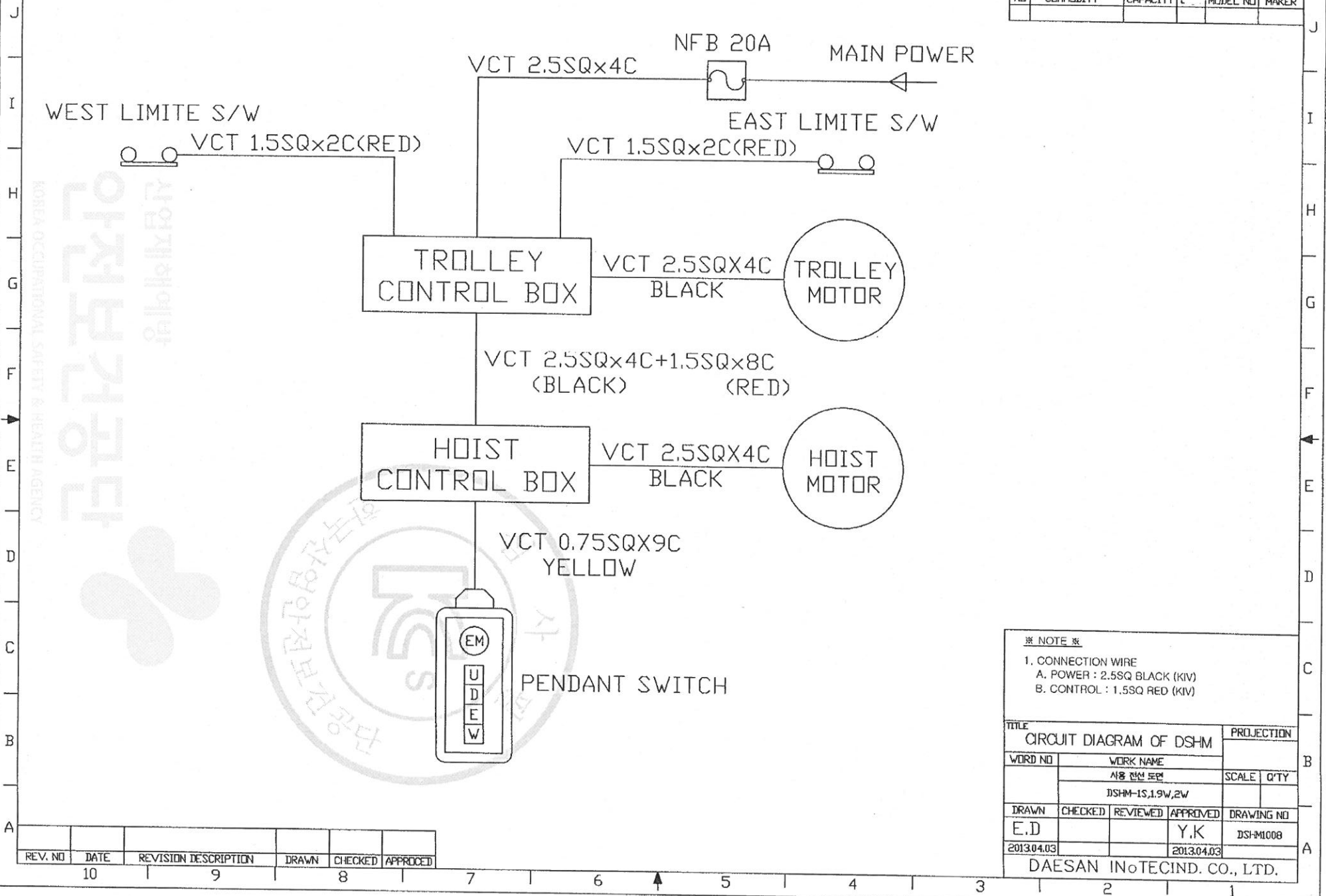

KOREA OCCUPATIONAL SAFETY & HEALTH AGENCY
 안전보건공단
 산업재해예방

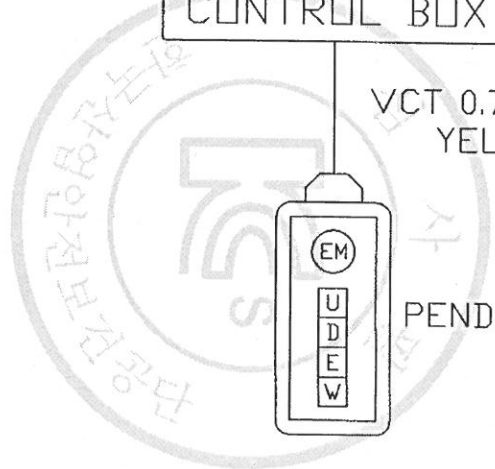

※ NOTE ※

- CONNECTION WIRE
 A. POWER : 2.5SQ BLACK (KIV)
 B. CONTROL : 1.5SQ RED (KIV)

TITLE				PROJECTION	
CIRCUIT DIAGRAM OF DSHM					
WORD NO	WORK NAME			SCALE	QTY
	시용 전선 도면				
	DSHM-1S,1.9W,2W				
DRAWN	CHECKED	REVIEWED	APPROVED	DRAWING NO	
E.D			Y.K	DSH-M1008	
2013.04.03			2013.04.03		

DAESAN INoTECIND. CO., LTD.

REV. NO	DATE	REVISION DESCRIPTION	DRAWN	CHECKED	APPROVED

10 9 8 7 6 5 4 3 2 1

불변복제 및 배포금지

192.168.0.11 / 2013-05-14 11:57:07

10 9 8 7 6 5 4 3 2 1

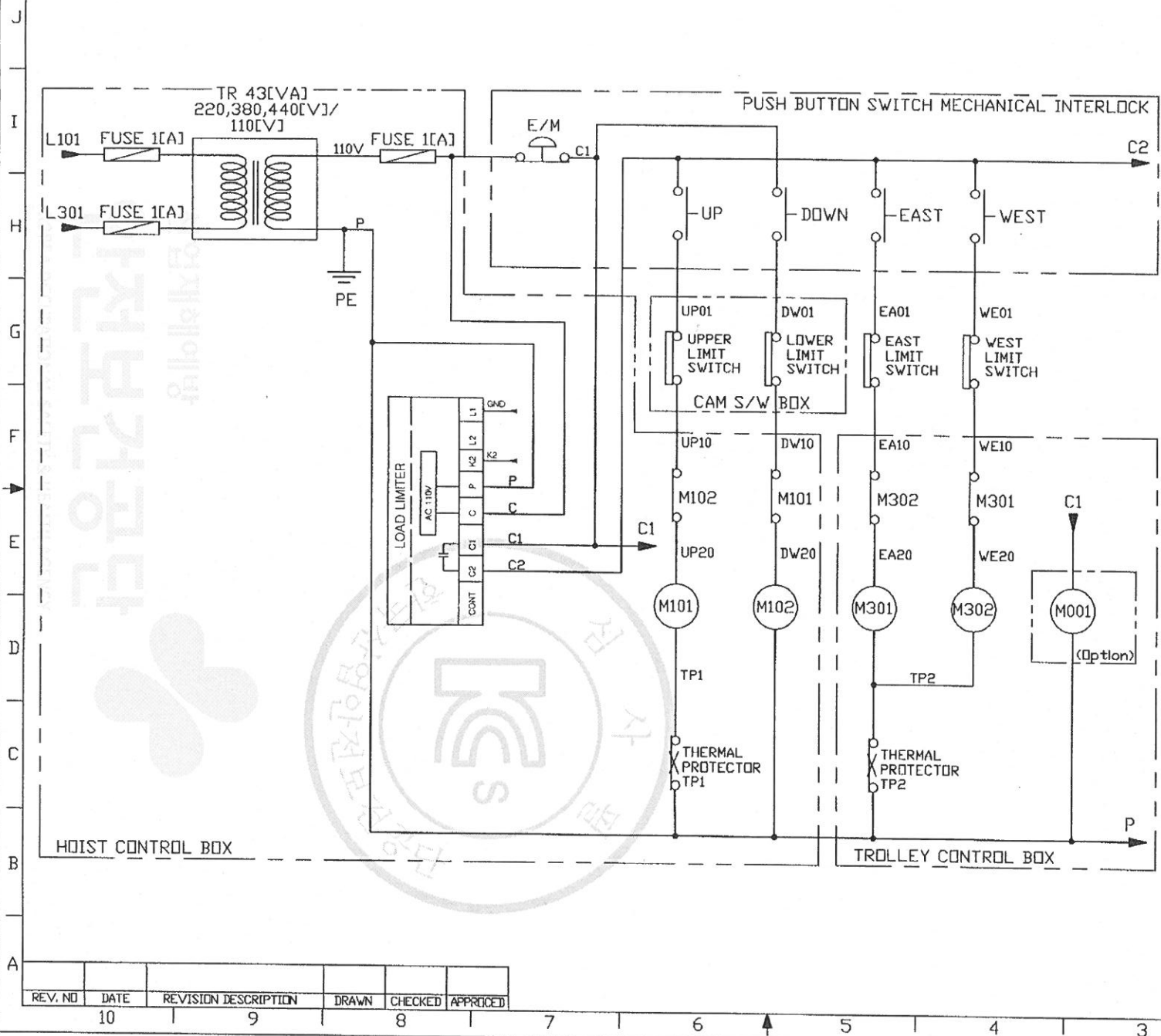

NO	COMMODITY	CAPACITY	MODEL NO	MAKER
1	MAGNETIC CONTACTOR	2.2KW	DMC-12b	DONG-A
2	TRANSFORMER	43VA	-	DAESAN
3	PUSH BUTTON S/W	4POINT	1024SEB	HANYUNG
4	LOAD LIMITER	70TON	JDL-100	JUNG-HD
5	CAM SWITCH	20A	2B	HANYUNG
6	LIMIT SWITCH	-	HY-M04	HANYUNG
7	FUSE	1A	-	LITTLE FUSE
8	FUSE HOLDER	3P	-	미성
9	TERMINAL BLOCK	6P	-	KAKIN

- ※ NOTE ※
- CONTROL WIER
- KM 1.5SQ (RED)
 - PUSH BUTTON SWITCH CABLE
- 0.75SQ * 7C
 - CAM SWITCH CABLE
- VCTF 1.5SQ * 4C
 - MAIN MAGNETIC CONTACTOR (M001)
- (OPTION)
 - EAST, WEST LIMIT SWITCH
- (OPTION)

TITLE				PROJECTION	
CIRCUIT DIAGRAM OF DSHM					
WORD NO	WORK NAME				
	CONTROL CIRCUIT DIAGRAM			SCALE	Q'TY
	DSH-M-1S,1.9W,2W				
DRAWN	CHECKED	REVIEWED	APPROVED	DRAWING NO	
E.D			Y.K	DSHM0001	
2013.04.03			2013.04.03		
DAESAN INOTECH. CO., LTD.					

REV. NO	DATE	REVISION DESCRIPTION	DRAWN	CHECKED	APPROVED
10					
9					
8					
7					

출판복제 및 배포금지

2013-05-14 11:57:07

192.168.0.11 / 2013-05-14 11:57:07

KOREA OCCUPATIONAL SAFETY & HEALTH AGENCY



불법복제 및 배포금지

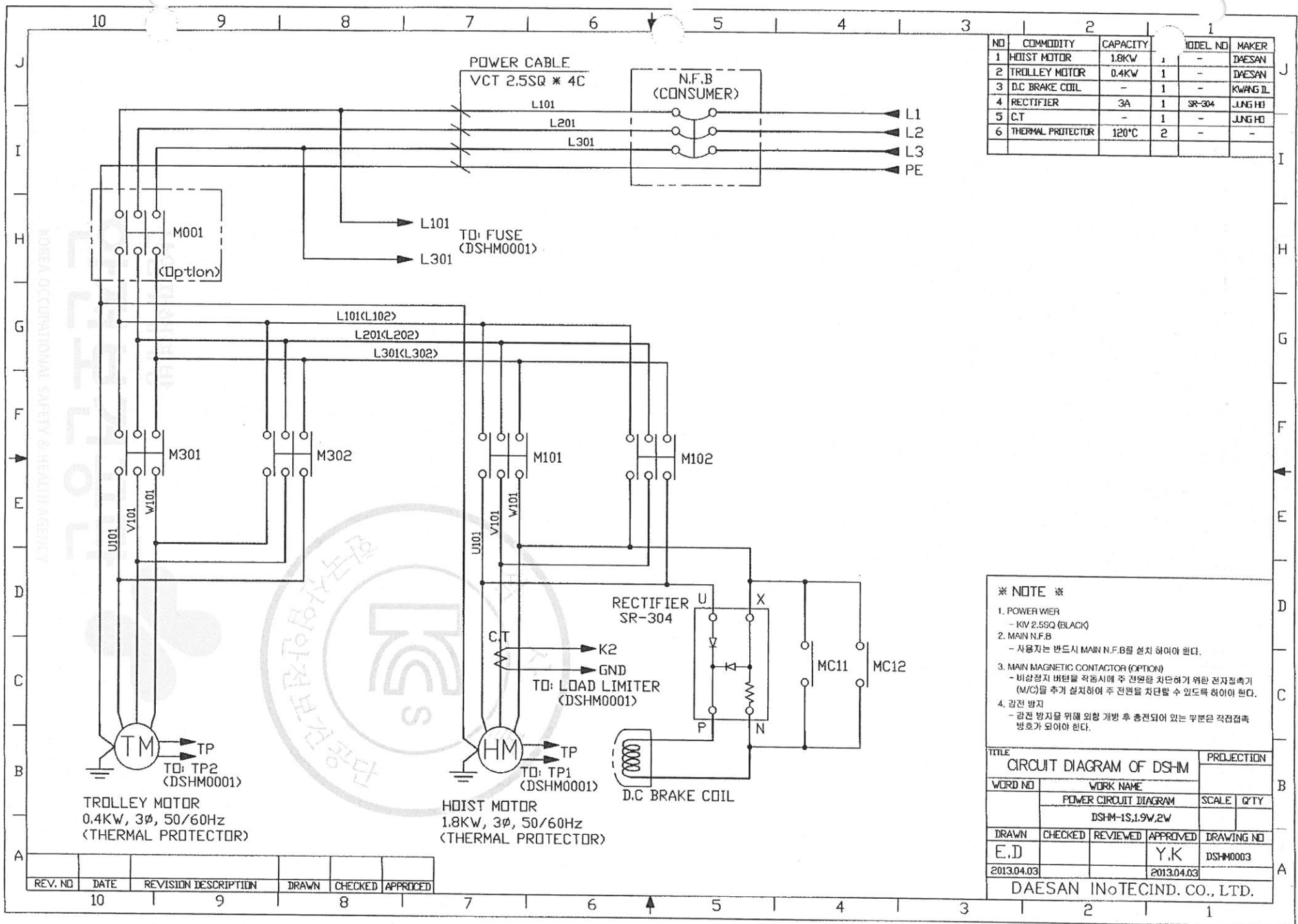

NO	COMMODITY	CAPACITY	MODEL NO	MAKER
1	HOIST MOTOR	1.8KW	-	DAESAN
2	TROLLEY MOTOR	0.4KW	-	DAESAN
3	D.C BRAKE COIL	-	-	KWANG IL
4	RECTIFIER	3A	SR-304	JUNG HO
5	C.T	-	-	JUNG HO
6	THERMAL PROTECTOR	120°C	2	-

※ NOTE ※

- POWER WIRE
- KIV 2.5SQ (BLACK)
- MAIN N.F.B
- 사용자는 반드시 MAIN N.F.B를 설치하여야 한다.
- MAIN MAGNETIC CONTACTOR (OPTION)
- 비상정지 버튼을 작동시킬 때 주 전원을 차단하기 위한 전자접속기 (M/C)를 추가 설치하여 주 전원을 차단할 수 있도록 하여야 한다.
- 감전 방지
- 감전 방지를 위해 위험 개방 후 충전되어 있는 부분은 직접접촉 방호가 되어야 한다.

TITLE				PROJECTION
CIRCUIT DIAGRAM OF DSHM				
WORD NO	WORK NAME		SCALE Q'TY	
	POWER CIRCUIT DIAGRAM			
	DSHM-1S,1.9W,2W			
DRAWN	CHECKED	REVIEWED	APPROVED	DRAWING NO
E.D			Y.K	DSHM0003
2013.04.03			2013.04.03	
DAESAN INoTECIND. CO., LTD.				

REV. NO	DATE	REVISION DESCRIPTION	DRAWN	CHECKED	APPROVED
10					
9					
8					
7					

192.168.0.11 / 2013-05-14 11:57:07

KOREA OCCUPATIONAL SAFETY & HEALTH AGENCY
 안전보건공단
 영남대학교

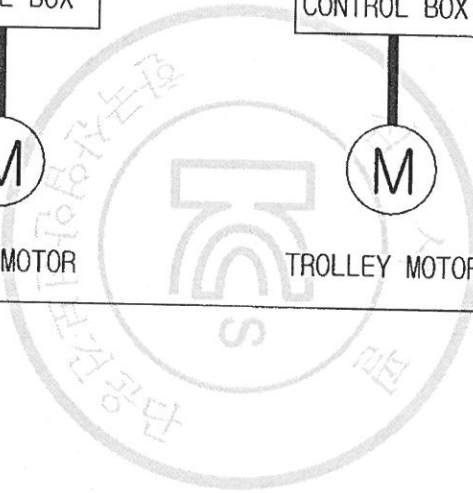

NO	COMMODITY	CAPACITY	MODEL NO	MAKER
1				

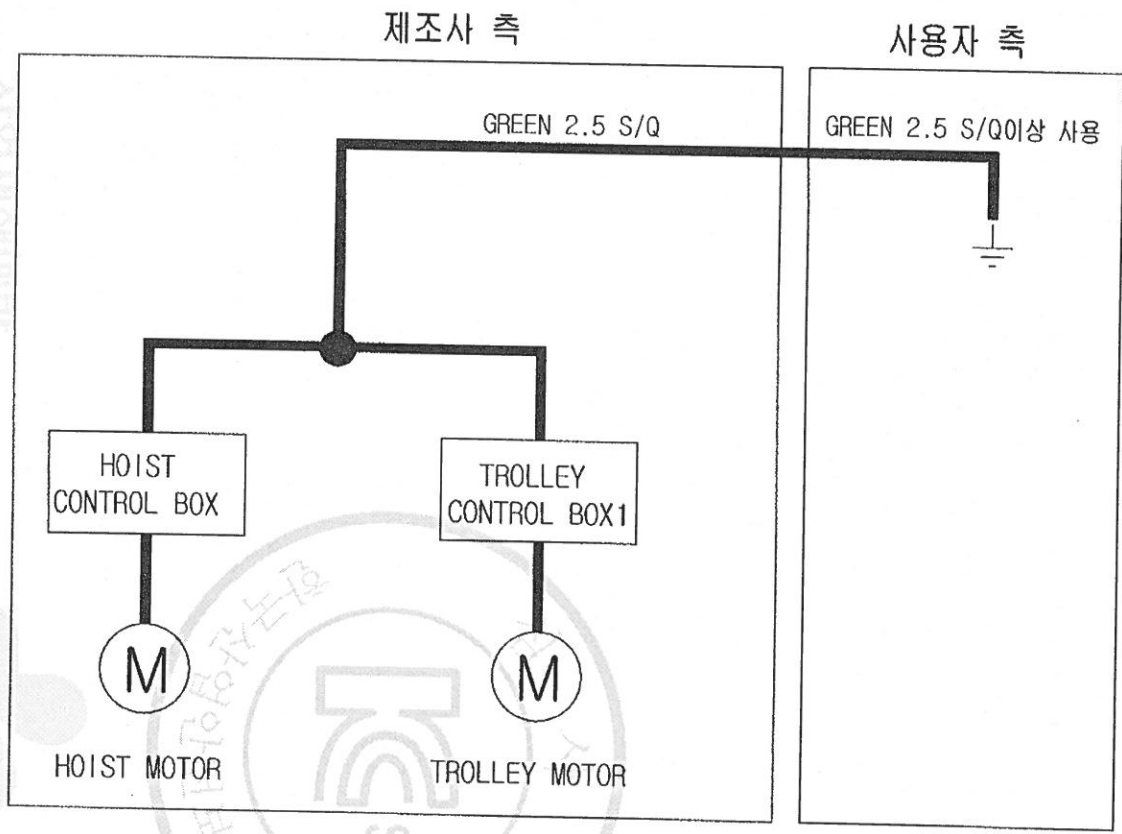

※ NOTE ※

TITLE CIRCUIT DIAGRAM OF DSHM				PROJECTION	
WORD NO	WORK NAME			SCALE Q'TY	
	전기 개명도				
	DSHM-1S.1.9W.2W				
DRAWN	CHECKED	REVIEWED	APPROVED	DRAWING NO	
E.D			Y.K		
2013.04.03		2013.04.03			
DAESAN InoTECIND. CO., LTD.					

REV. NO	DATE	REVISION DESCRIPTION	DRAWN	CHECKED	APPROVED

물범복제 및 배포금지

DSHM-1.9T I-BEAM CALCULATION SHEET

	I-200x100x7/10	I-250x125x7.5/12.5	I-300x150x7.5/18.5
SPAN L=CM	280	450	600
$I_x(\text{Cm}^4)$	2170	5180	12700
$I_y(\text{Cm}^4)$	138	337	886
$Z_x(\text{Cm}^3)$	217	414	849
$Z_y(\text{Cm}^3)$	28	53.9	118
$\sigma A(\text{Kg. Cm}^2)$	991.17	865.98	564.83
$\delta(\text{Cm})$	0.231	0.413	0.392
δ/L	1/1212	1/1090	1/1532



산업재해예방
안전보건공단
 KOSHA OCCUPATIONAL SAFETY & HEALTH AGENCY

호이스트 스위치

전자 조작용 개폐 스위치 (HOIST SWITCH)

- 전동 HOIST조작용으로 현수식 늘름버튼형 개폐기입니다.
- 방수형의 구조이며 외곽케이스는 기계적 강도 및 전기적 특성이 우수한 수지를 사용하여 가볍고 견고하게 설계되었습니다.
- 스위치 자체에 전원 단절용으로 주회로를 개폐할 수 있는 구조로 되어 있습니다.
- 접점 부분은 1단(1a)이 기본이며, 전동기 속도 제어용에 필요한 2단 접점이 있어 필요 부분에 부착 사용할 수 있도록 설계되어 있습니다.
- 풍부한 버튼 문자판이 준비되어 있어 용도에 맞추어 선택 사용이 용이합니다.
- 소형 및 경량으로 설계되어 경제적입니다.
- 걸고리가 장착되어 사용이 편리합니다.



■ 구조

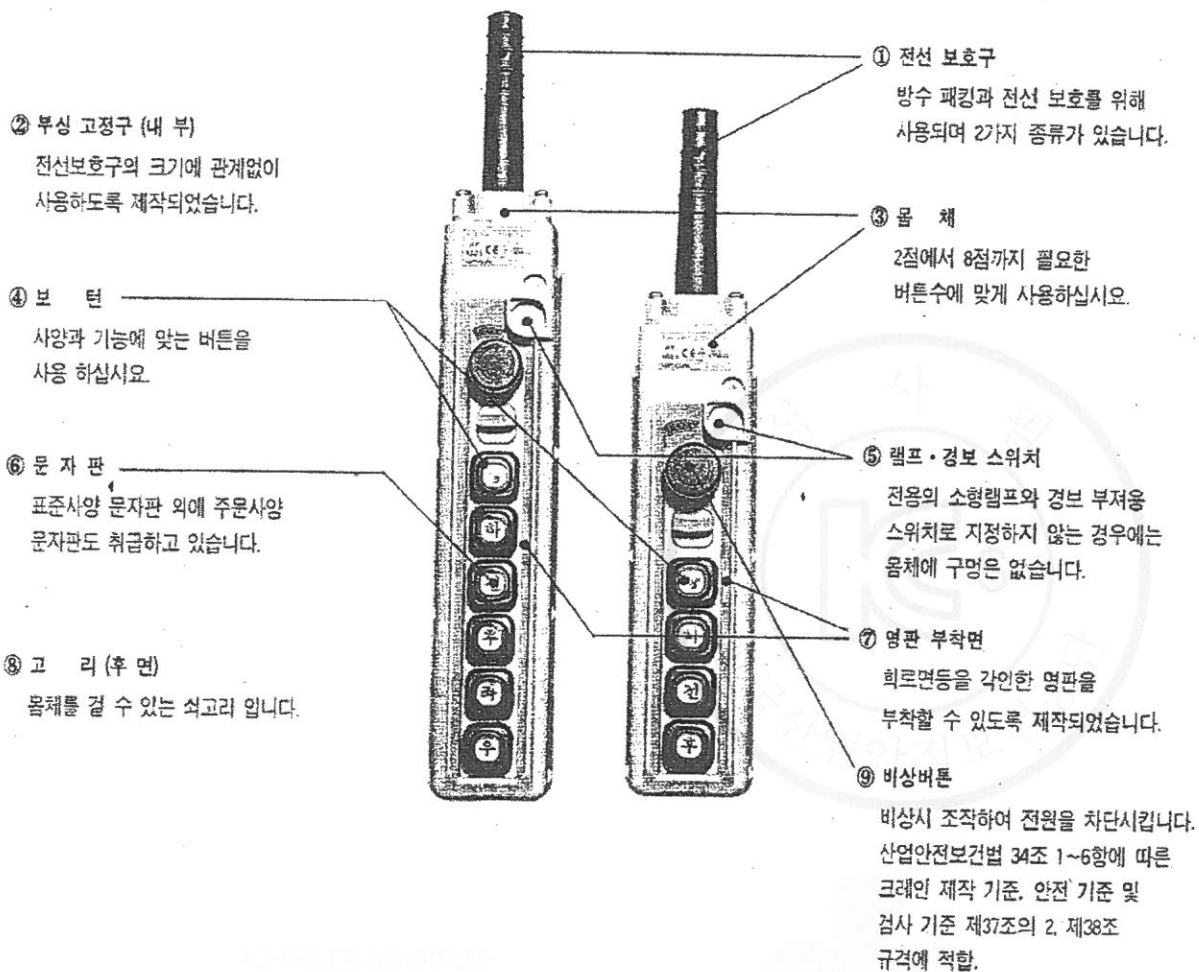

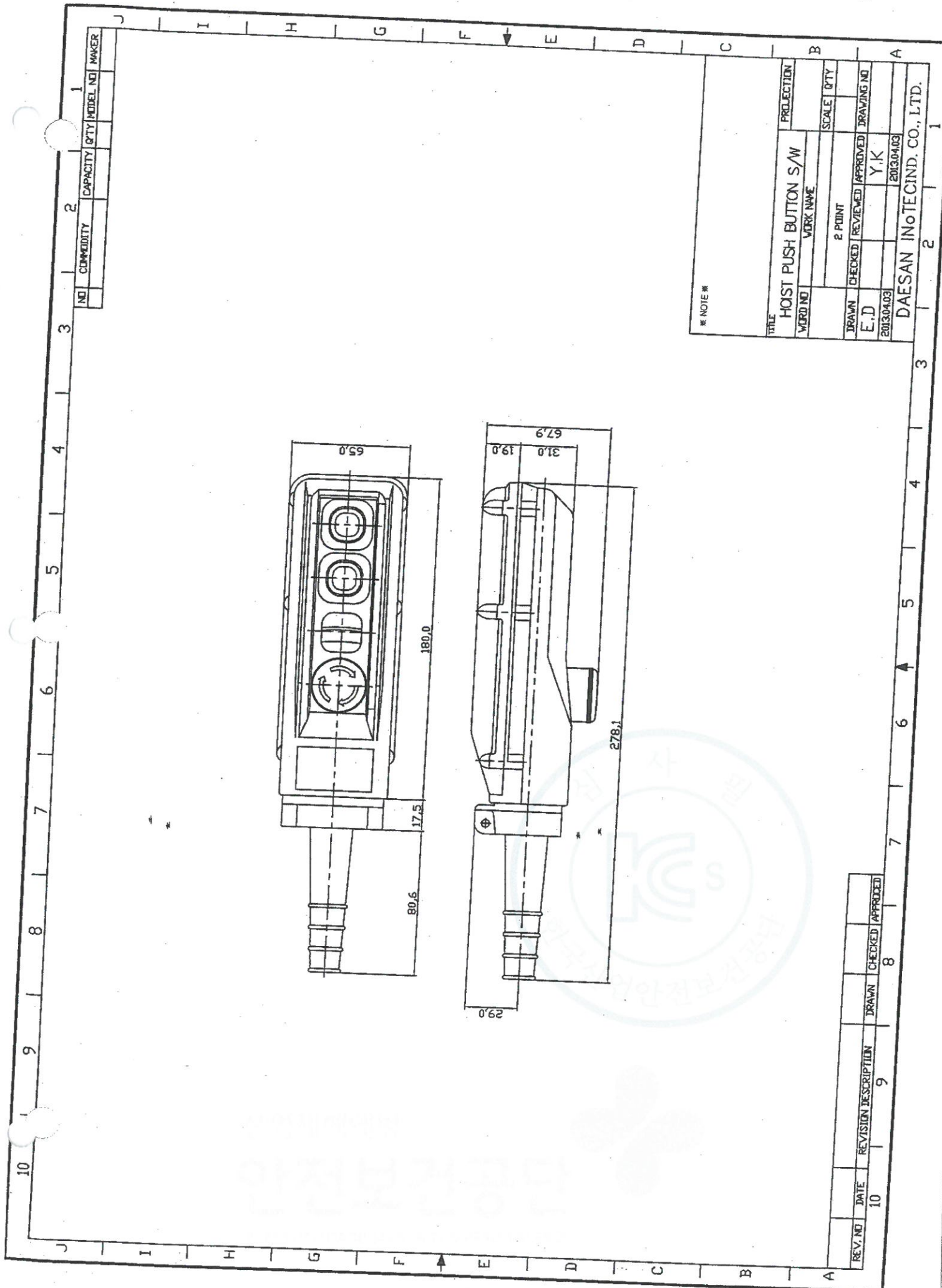

NO	COMMODITY	CAPACITY	QTY	MODEL NO	MAKER

* NOTE *		PROJECTION	
TITLE HOIST PUSH BUTTON S/W		SCALE	
MEMO NO	WORK NAME	2 POINT	QTY
DRAWN	CHECKED	REVIEWED	APPROVED
E.D		Y.K	
2013.04.03		2013.04.03	
DAESAN INOTECHIND. CO., LTD.			

REV. NO	DATE	REVISION DESCRIPTION	DRAWN	CHECKED	APPROVED
10					

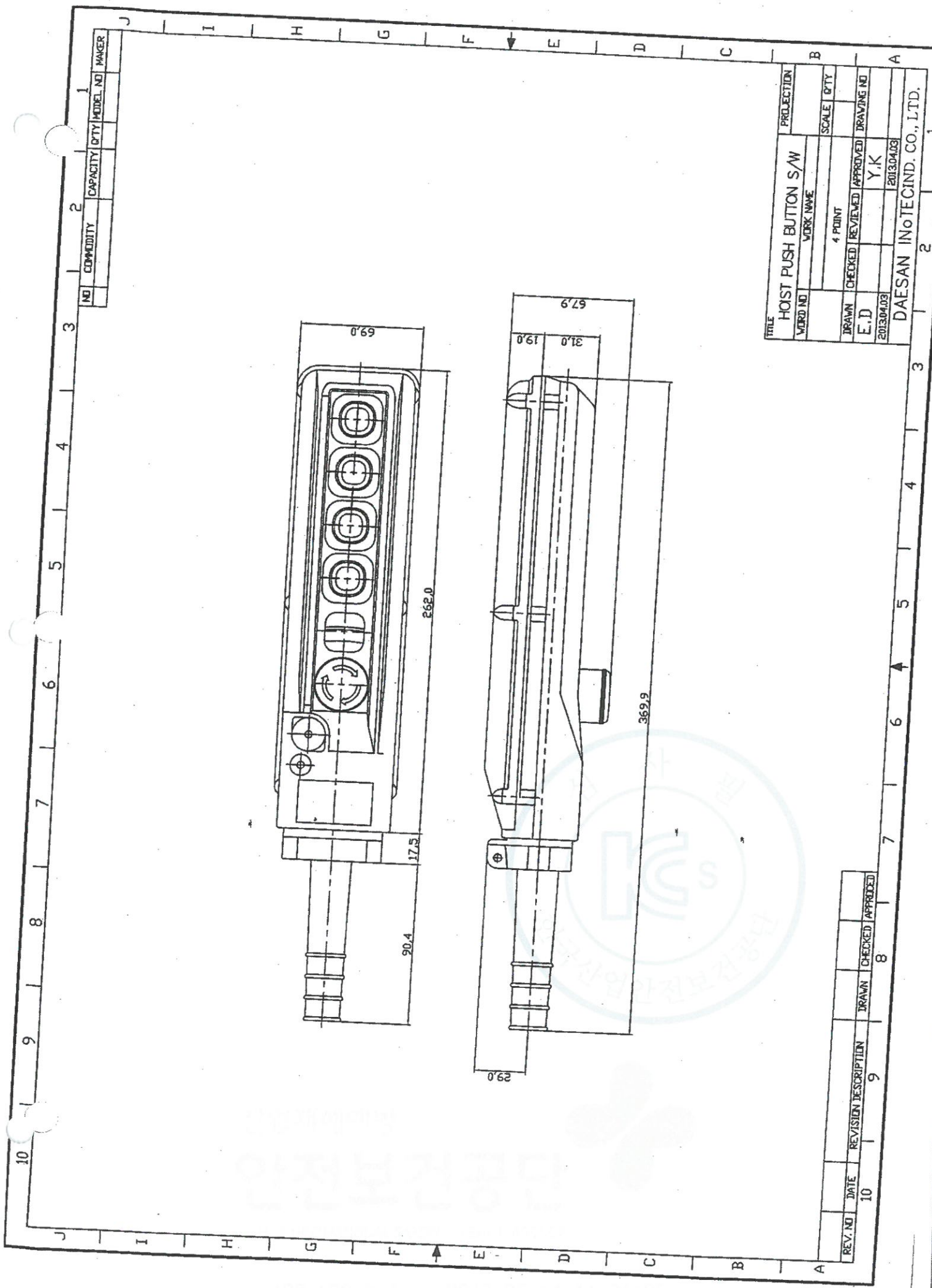

NO	COMMODITY	CAPACITY	QTY	MODEL NO	MAKER
1					

TITLE		HOIST PUSH BUTTON S/W		PROJECTION	
WORD NO	WORK NAME			SCALE	QTY
	4 POINT				
DRAWN	CHECKED	REVIEWED	APPROVED	DRAWING NO	
E.D		Y,K			
2013.04.03				2013.04.03	
DAESAN INOTECHIND. CO., LTD.					

REV. NO	DATE	REVISION DESCRIPTION	DRAWN	CHECKED	APPROVED
10					

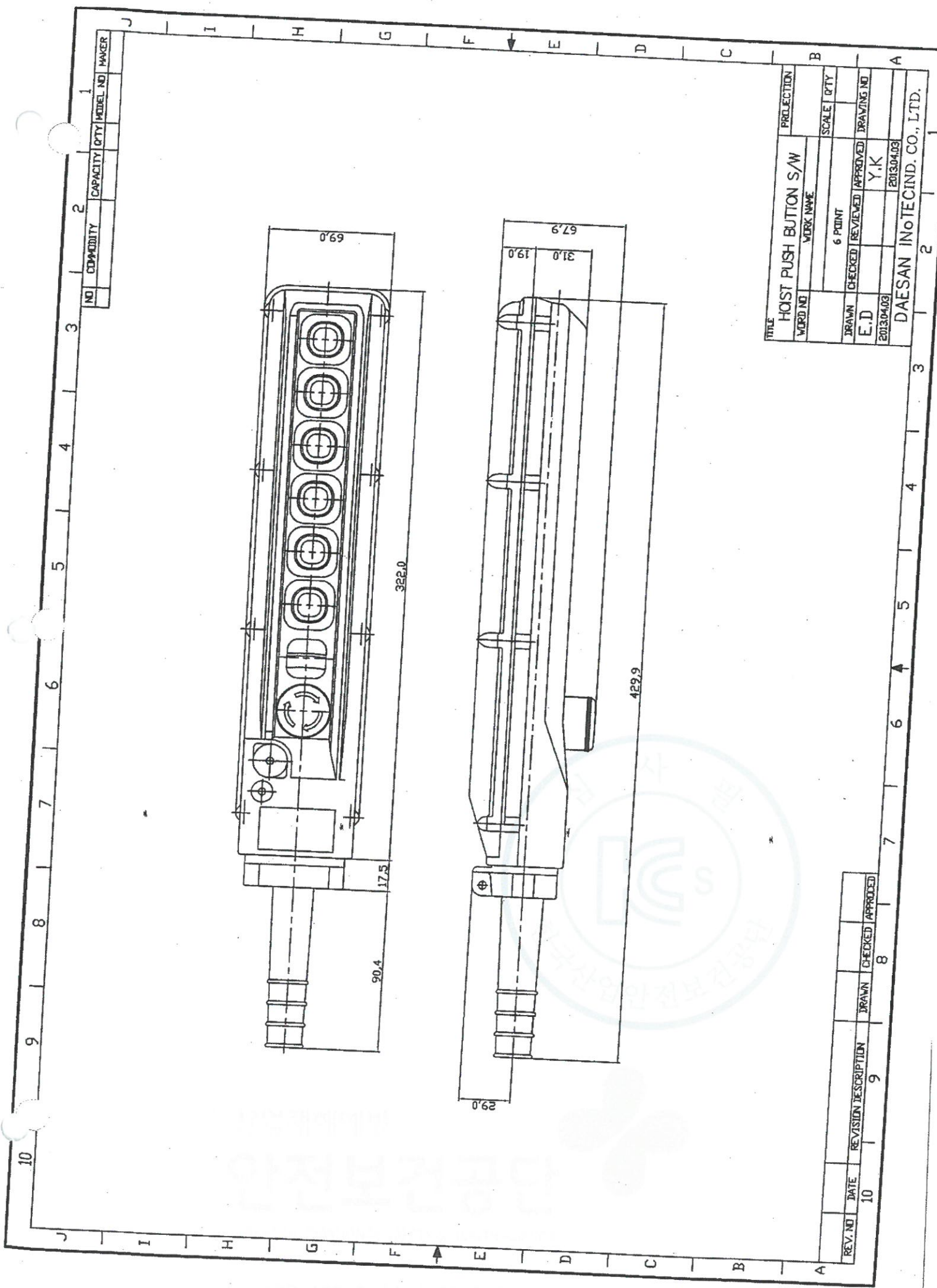

NO	COMMODITY	CAPACITY	QTY	MODEL NO	MAKER
1					

TITLE		PROJECTION	
HOIST PUSH BUTTON S/W			
WORD NO	WORK NAME	SCALE	QTY
		6 POINT	
DRAWN	CHECKED	REVIEWED	APPROVED
E.D		Y.K	
2013.04.03		2013.04.03	
DAESAN INOTECHIND. CO., LTD.			

REV. NO	DATE	REVISION DESCRIPTION	DRAWN	CHECKED	APPROVED
10				8	

SCHEDULE OF TECHNICAL DATA

1. SERVICE	HOISTING
2. MANUFACTURE	DAESAN INOTEC INC.
3. MOTOR MODEL NO.	DSAI - 1S - 220
4. RATED POWER	1.8 KW x 4 P
5. RATED VOLTAGE AND FREQUENCY	220 V 60 HZ
6. MOTOR TYPE	SQUIRREL CAGE ROTOR YPE
7. RATING	30 MIN
8. LOCATION	IN-DOOR , OUT-DOOR
9. INSULATION CLASS	B
10. DESING TEMPERATURE RISE (BY RESISTANCE)	80°C
11. FULL LOAD SPEED	1740 RPM
12. FULL LOAD CURRENT	9.4 A
13. STARTING CURRENT AT RATED VOLTAGE	47.0 A
14. MINIMUM STATING VOLTAGE	198 V
15. EFFICIENCY AT 100% RAGED LOAD	72.0%
16. POWER FACTOR AT 100% RATED LOAD	70.0%
17. STARTING TORQUE	238%
18. TYPE OF ENCLOSURE	전폐형
19. TYPE OF BEARING	PL : 6008DD OPL : 6207ZZ
20. MOUNTING	VERTICAL
21. MAXIMUM AMBIENT TEMPURE	40°C
22. BEARING LUBRICATION	GREASE
23. STARTING METHOD	FULL VOLTAGE

SCHEDULE OF TECHNICAL DATA

1. SERVICE	HOISTING
2. MANUFACTURE	DAESAN INOTEC INC.
3. MOTOR MODEL NO.	DSAI - 1S - 380
4. RATED POWER	1.8 KW x 4 P
5. RATED VOLTAGE AND FREQUENCY	380 V 60 HZ
6. MOTOR TYPE	SQUIRREL CAGE ROTOR YPE
7. RATING	30 MIN
8. LOCATION	IN-DOOR , OUT-DOOR
9. INSULATION CLASS	B
10. DESING TEMPERATURE RISE (BY RESISTANCE)	80°C
11. FULL LOAD SPEED	1740 RPM
12. FULL LOAD CURRENT	5.5 A
13. STARTING CURRENT AT RATED VOLTAGE	26.8 A
14. MINIMUM STATING VOLTAGE	342 V
15. EFFICIENCY AT 100% RAGED LOAD	72.5%
16. POWER FACTOR AT 100% RATED LOAD	68.8%
17. STARTING TORQUE	243%
18. TYPE OF ENCLOSURE	전폐형
19. TYPE OF BEARING	PL : 6008DD OPL : 6207ZZ
20. MOUNTING	VERTICAL
21. MAXIMUM AMBIENT TEMPURE	40°C
22. BEARING LUBRICATION	GREASE
23. STARTING METHOD	FULL VOLTAGE

SCHEDULE OF TECHNICAL DATA

1. SERVICE	HOISTING
2. MANUFACTURE	DAESAN INOTEC INC.
3. MOTOR MODEL NO.	DSAI - 1S - 440
4. RATED POWER	1.8 KW x 4 P
5. RATED VOLTAGE AND FREQUENCY	440 V 60 HZ
6. MOTOR TYPE	SQUIRREL CAGE ROTOR YPE
7. RATING	30 MIN
8. LOCATION	IN-DOOR , OUT-DOOR
9. INSULATION CLASS	B
10. DESING TEMPERATURE RISE (BY RESISTANCE)	80°C
11. FULL LOAD SPEED	1740 RPM
12. FULL LOAD CURRENT	4.7 A
13. STARTING CURRENT AT RATED VOLTAGE	22.8 A
14. MINIMUM STATING VOLTAGE	396 V
15. EFFICIENCY AT 100% RAGED LOAD	71.9%
16. POWER FACTOR AT 100% RATED LOAD	69.8%
17. STARTING TORQUE	245%
18. TYPE OF ENCLOSURE	전폐형
19. TYPE OF BEARING	PL : 6008DD OPL : 6207ZZ
20. MOUNTING	VERTICAL
21. MAXIMUM AMBIENT TEMPURE	40°C
22. BEARING LUBRICATION	GREASE
23. STARTING METHOD	FULL VOLTAGE

SCHEDULE OF TECHNICAL DATA

1. SERVICE	TRAVERSING
2. MANUFACTURE	DAESAN INOTEC INC.
3. MOTOR MODEL NO.	MT - 1 - 220
4. RATED POWER	0.4 KW x 6 P
5. RATED VOLTAGE AND FREQUENCY	220 V 60 HZ
6. MOTOR TYPE	SQUIRREL CAGE ROTOR YPE
7. RATING	30 MIN
8. LOCATION	IN-DOOR
9. INSULATION CLASS	B
10. DESING TEMPERATURE RISE (BY RESISTANCE)	100°C
11. FULL LOAD SPEED	1140 RPM
12. FULL LOAD CURRENT	3.3 A
13. STARTING CURRENT AT RATED VOLTAGE	13.9 A
14. MINIMUM STATING VOLTAGE	198V
15. EFFICIENCY AT 100% RAGED LOAD	57.5%
16. POWER FACTOR AT 100% RATED LOAD	54.5%
17. STARTING TORQUE	249%
18. TYPE OF ENCLOSURE	전폐형
19. TYPE OF BEARING	PL : 6202DD OPL : 6204ZZ
20. MOUNTING	VERTICAL
21. MAXIMUM AMBIENT TEMPURE	40°C
22. BEARING LUBRICATION	GREASE
23. STARTING METHOD	FULL VOLTAGE

SCHEDULE OF TECHNICAL DATA

1. SERVICE	TRAVERSING
2. MANUFACTURE	DAESAN INOTEC INC.
3. MOTOR MODEL NO.	MT - 1 - 380
4. RATED POWER	0.4 KW x 6 P
5. RATED VOLTAGE AND FREQUENCY	380 V 60 HZ
6. MOTOR TYPE	SQUIRREL CAGE ROTOR YPE
7. RATING	30 MIN
8. LOCATION	IN-DOOR
9. INSULATION CLASS	B
10. DESING TEMPERATURE RISE (BY RESISTANCE)	100°C
11. FULL LOAD SPEED	1140 RPM
12. FULL LOAD CURRENT	1.7 A
13. STARTING CURRENT AT RATED VOLTAGE	9.2 A
14. MINIMUM STATING VOLTAGE	342V
15. EFFICIENCY AT 100% RAGED LOAD	53.0%
16. POWER FACTOR AT 100% RATED LOAD	51.0%
17. STARTING TORQUE	249%
18. TYPE OF ENCLOSURE	전폐형
19. TYPE OF BEARING	PL : 6202DD OPL : 6204ZZ
20. MOUNTING	VERTICAL
21. MAXIMUM AMBIENT TEMPURE	40°C
22. BEARING LUBRICATION	GREASE
23. STARTING METHOD	FULL VOLTAGE

SCHEDULE OF TECHNICAL DATA

1. SERVICE	TRAVERSING
2. MANUFACTURE	DAESAN INOTEC INC.
3. MOTOR MODEL NO.	MT - 1 - 440
4. RATED POWER	0.4 KW x 6 P
5. RATED VOLTAGE AND FREQUENCY	440 V 60 HZ
6. MOTOR TYPE	SQUIRREL CAGE ROTOR YPE
7. RATING	30 MIN
8. LOCATION	IN-DOOR
9. INSULATION CLASS	B
10. DESING TEMPERATURE RISE (BY RESISTANCE)	100°C
11. FULL LOAD SPEED	1140 RPM
12. FULL LOAD CURRENT	1.5 A
13. STARTING CURRENT AT RATED VOLTAGE	9.2 A
14. MINIMUM STATING VOLTAGE	396V
15. EFFICIENCY AT 100% RAGED LOAD	55.3%
16. POWER FACTOR AT 100% RATED LOAD	57.2%
17. STARTING TORQUE	249%
18. TYPE OF ENCLOSURE	전폐형
19. TYPE OF BEARING	PL : 6202DD OPL : 6204ZZ
20. MOUNTING	VERTICAL
21. MAXIMUM AMBIENT TEMPURE	40°C
22. BEARING LUBRICATION	GREASE
23. STARTING METHOD	FULL VOLTAGE

FEC CHAIN CORPORATION TEL:+81-53-425-4116 , 2162		337 KANAORI-CHO , HAMAMATSU CITY, SHIZUOKA PRE.,435-0026 JAPAN FAX:+81-53-425-5122	
TEST CERTIFICATE			
Distributor:	code #: 1080	distributor's name: ASAO & CO., LTD	
Coustermer:		coustermer's name:	
Article name: (Application)	Load chain for electric chain hoist		
Spec. standard	<input type="checkbox"/> DIN EN 818-7:2002 , <input type="checkbox"/> JIS B 8812:1999 <input type="checkbox"/> ISO 3077 , <input checked="" type="checkbox"/> FEC		
Material spec.:	SAE15B24(Mn-B steel)		
Finish:	<input type="checkbox"/> temper-colored, <input checked="" type="checkbox"/> electroless nickel-plated, <input type="checkbox"/> coated() <input type="checkbox"/> zinc-phosphated, <input type="checkbox"/> manganese-phosphated <input checked="" type="checkbox"/> oiled, <input type="checkbox"/> no-oiled		
Stamping:	<input type="checkbox"/> FEC standard, <input checked="" type="checkbox"/> coustermer's request → DS, JAPAN , (Lot #), FEC#		
Product code#:	FCD07121		
description:	φ 7.1*P21		
quality type	G80/ type-DAT		
Dimention:			Result
Nominal diameter(dn)	[mm]	7.1 +0.0/-0.3	OK
Internal width,min.:	[mm]	8.8	
external width, max.:	[mm]	23.6	
Nominal pitch 1 t	[mm]	21.0 +0.3/-0.1	
5 t	[mm]	-	
11 t	[mm]	231.0 +0.3/-0.7	
Diameter at the weld(ds), max.:	[mm]	7.6	
Mechanical properties:			OK
Working load limit(WLL), max.:	[kg]	1500	
(drive mechanism g			
Manufacturing proof force(MPF), min.:	[KN]	40	
Stress at min. MPF		-	
Guranteed breaking force(BF), min.:	[KN]	63	
Stress at min. BF		-	
Total ultimate elongation(A), min.:	[%]	10	
Surface hardness/HV3, min.:	[-]	500	
/HV5, min.:	[-]	-	
Hardness /HRC, min.:	[-]	-	
Case depth,min.:	[mm]	0.14	
Bend deflection(f),min.:	[mm]	-	
Fatigue resistance, min.:	[cycle]	-	
Packing:			
Weight per meter:	[kg/m]	1.1	
Length 1	[meter]	200m-1pc	
2	[meter]	-	
Packing		Steel barrel	
I hereby certify above all is true.		K. Sugimura KAZUYUKI SUGIMURA Quality Assurance Dept., Chief Inspector	
issued date:	November 29,2011		
[Note]			

제 2012-BJ-0009 호



안 전 인 증 서

정호엔지니어링

경기도 광명시 노동사동 440-5

위 사업장에서 제조하는 아래의 품목이 산업안전보건법 제34조 및 같은 법 시행규칙 제58조의4제4항에 따른 안전인증 심사 결과 안전·보건기준에 적합하므로 안전인증표시의 사용을 인증합니다.

_____ 품 목 _____
양중기용 과부하방지장치

_____ 형식·모델/용량·등급/인증번호 _____
형식·모델 용량·등급 인증번호
JDL-100 J-2 12-AV2BJ-0009

_____ 인 증 기 준 _____
방호장치 의무안전인증 고시(고용노동부고시 제2010-36호)

_____ 인 증 조 건 _____
아래 주소에서 생산되는 제품에 한함.
정호엔지니어링, 경기도 광명시 노동사동 440-5

2012년 06월 11일

한국산업안전보건공단 이사장

