



Ex -Proof Manual

CHAIN HOIST [1,2,3,5,10TON] PLAIN & GEARED TROLLEYS[1,2,3,5,10]

EXPLOSION PROTECTION & SPARK RESISTANCE

Designed for explosive environments with spark-resistant, full bronze suspension and load hooks; stainless steel hand chain and electroless nickel plated load chain ; and bronze wheels for trolley with safety drop stop and rubber bumper

CORROSION RESISTANT

Enclosed robust electroless nickel plated housing protects internal components, even in the toughest conditions.

- *ATEX marking :
EX II 2 GDC IIC T4 T + 135 °C
- *Suitable for gas & dust hazardous areas :
zone 1&2, zone 21&22
- *Stainless steel Load chain(SUS316L)
- *Stainless steel hand chain (SUS304)
- *Electroless nickel plated load chain
- *Bronze wheel

Option



Hoist body weather cover



Stainless steel frame canvas chain box



Overload protection device

*This option is available for all chain blocks and spark resistant chain hoists.
* Chain box types: stainless steel frame canvas chain box and steel frame canvas chain box.



- Spark Resistant Chain Hoist

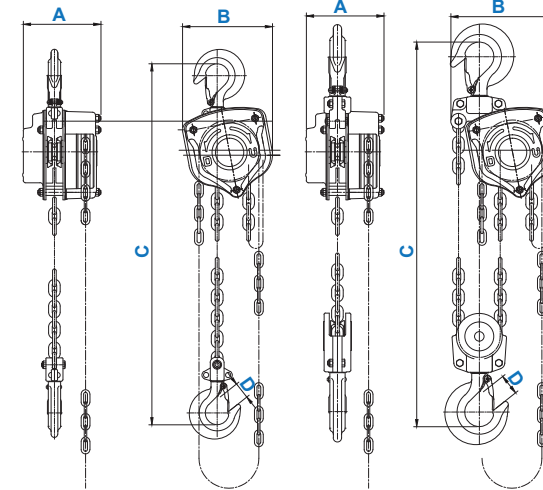

EX DSN TYPE

MODEL NO : EX DSN		1	2	3	5	10
Capacity (Nickel plated load chain)	(ton)	1	2	3	5	10
Hand chain force	(kg)	33	34	35	39	41
Hand chain operation length	(m)	2.5	3	3	3	3.5
Number of chain falls	(no.)	1	1	2	2	4
Load chain size	(mm)	6.3 x 19.1	7.9 x 23.0	7.1 x 21.0	9.0 x 27.0	9.0 x 27.0
Min headroom (C)	(mm)	330	380	480	620	820
A (Dimension)	(mm)	147	184	147	185	185
B		145	187	206	258	367
D		30	38	42	45	53
Net weight with standard lift	(kg)	12	22	23	41	95
Net weight per m additional lift	(kg)	1.36	1.86	2.7	4.02	7.54

*In case of applying stainless steel load chain, it is recommended to use 60% of rated load.

*The above specification is subject to change for stainless steel load chain application.



- Spark Resistant plain & geared traveling trolley

EX DP,DG TYPE

MODEL NO :	EX DP	1	2	3	5	10
	EX DG	1	2	3	5	10
Capacity	(ton)	1	2	3	5	10
Hand chain force	(kg)	10	16	20	20	19
Hand chain operation length	(m)	2.5	3	3	3	3.5
Flange width	(mm)	75 - 125	100 - 150	100 - 150	125 - 175	125 - 200
Min curve radius	(mm)	1300	1500	2000	2500	2600
A (Dimension)	(mm)	399	439	480	519	536
B		122	142	163	183	183
C		221.5	253	269.5	300.5	376
D		142.5	160	169	185.5	249
E		79	93	100.5	116	127
G		80	100	113	125	125
I		49	63	78.5	97.5	106
K		26	32	38	50	70
L		305.5	336	351.5	383	448.5
M		22	32	40	45	60
Net weight EXDP TYPE (Standard)	(kg)	15	25	38	48	69
Net weight EXDG TYPE (Standard)	(kg)	18	28	40	58	79

*Explosion protected version with spark resistant coating



Corrosion protection (Basic/Medium)

EXDP & EXDG-trolleys have outstanding corrosion protection. All steel parts are electroless nickel plated. This is a must in wet rooms and in very aggressive environment. Larger flange width are optional. Wheels fit flat and also tapered flanges!

