

NO	DESCRIPTION	MAT'L	Q'TY	WT(kg)	REMARKS

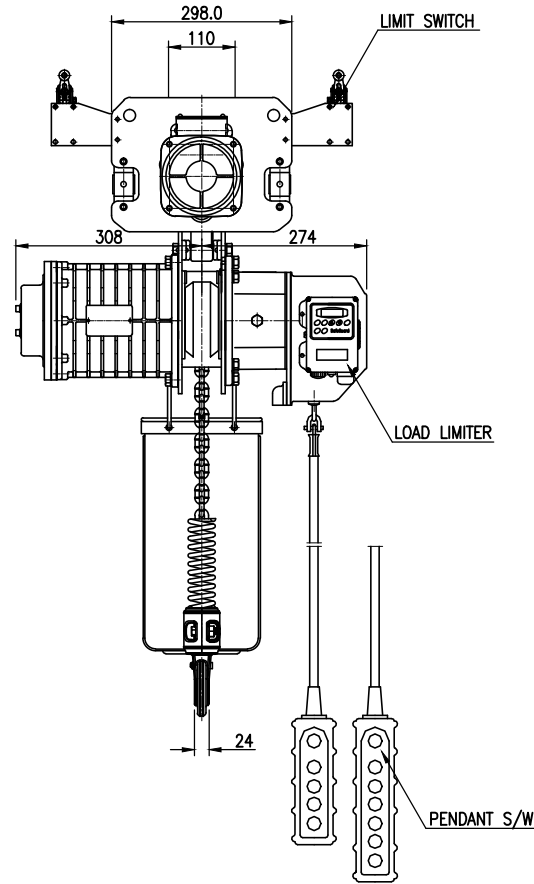
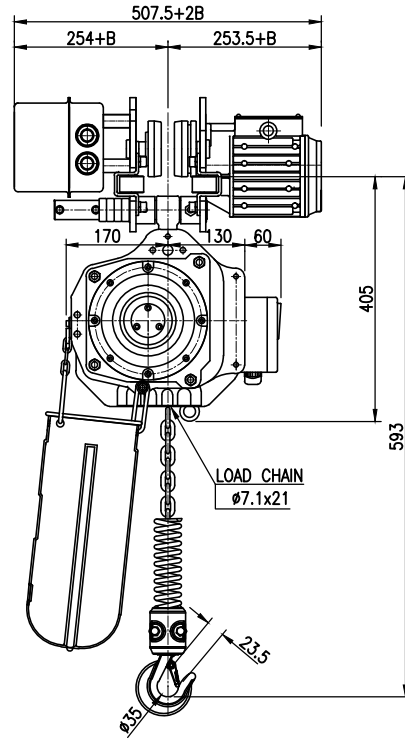

SPECIFICATION			
HOISTING LOAD	1 TON		
TESTING LOAD	1.25 TON		
LIFTING HEIGHT	5 M		
HOISTING	SPEED	50/60Hz	6.8/8.2 M/MIN
	MOTOR	1.8 KW x 4P x 1 SET	
TRAVERSING	SPEED	50/60Hz	12/15 M/MIN
	MOTOR	0.4 KW x 6P x 1 SET	
POWER SUPPLY	AC 220, 380, 440, 460 x 3φ x 60 Hz		
OPERATING METHOD	P.B type ON . FL		
WEIGHT	105 KG		
I-BEAM SIZE	75-125		

NOTE

- * B 는 BEAM 변동 치수임.
- * ROLLER DIA : $\varnothing 95$
- * LIMIT SWITCH : OPTION
- * 본 도면은 I-BEAM 75MM 기준임.

TITLE DSM-1S CHAIN HOIST				PROJECTION	
WORK NO	WORK NAME				
				SCALE	Q'TY
				1/1	1
DRAWN	CHECKED	REVIEWED	APPROVED	CODE NO	
H.J	-	LEE. H.J	Y. K	DSM01S001	
2021.02.24	-	2021.02.24	2021.02.24		

도면에 지시되지 않은 일반공차						
가공법	치수	3-6	6-30	30-120	120-315	315-1000
선	삭	±0.1	±0.2	±0.3	±0.5	±0.8
구멍간	거리	±0.1	±0.2	±0.3	±0.5	±0.8

REV.NO	DATE	REVISION DESCRIPTION	DRAWN	CHECKED	APPROVED

DAESAN INoTEC INC