

NO	DESCRIPTION	MAT'L	Q'TY	WT(kg)	REMARKS

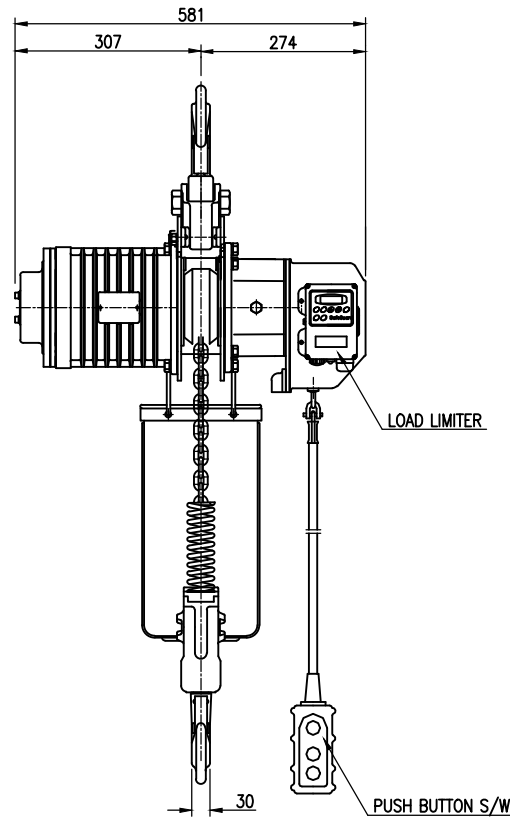
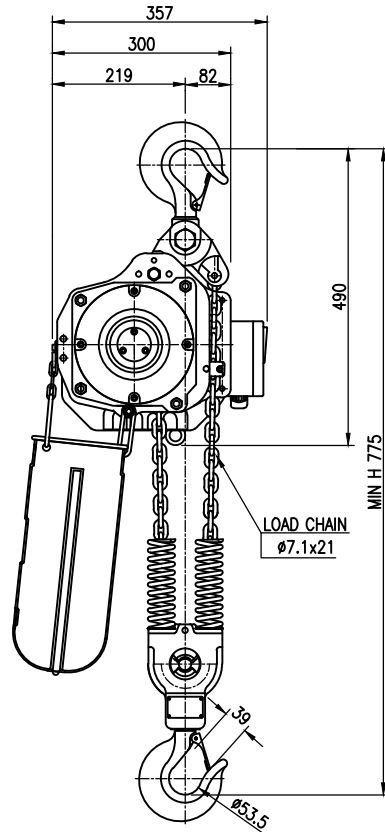

SPECIFICATION			
HOISTING LOAD	1.9	TON	
TESTING LOAD	2.375	TON	
LIFTING HEIGHT	4	M	
HOISTING	SPEED	50/60Hz	3.4/4.1 M/MIN
	MOTOR	1.8 KW x 1 SET	
POWER SUPPLY	AC 220, 380, 440 x 3ø x 50/60 Hz		
OPERATING METHOD	P.B type ON . FL		
WEIGHT	85 KG		

TITLE DSA-1.9W CHAIN HOIST				PROJECTION	
WORK NO		WORK NAME			
				SCALE	Q'TY
				1/1	1
DRAWN	CHECKED	REVIEWED	APPROVED	DRAWING NO	
YOO.M.R	-	LEE. H.J	Y.K	DSA19W001	
2012.07.11	-	2012.07.11	2012.10.17		

REV.NO	DATE	REVISION DESCRIPTION	DRAWN	CHECKED	APPROVED

DAESAN INoTEC INC